

1. PARTS LIST / STATION

NOTE:
Spare or repair parts do not include mounting screws, if they are not listed on the specifications. Screws must be ordered separately.

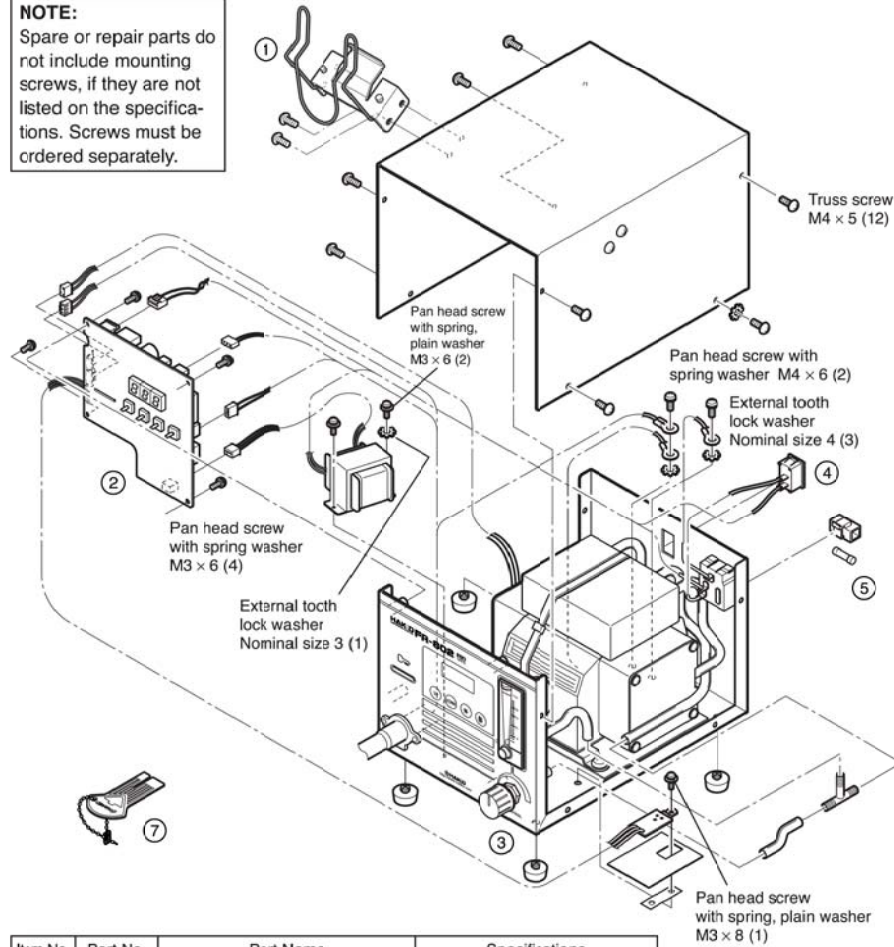

Item No.	Part No.	Part Name	Specifications
①	B3442	Handpiece holder	
②	B3378	P.W.B./for temperature control	100~120V, with triac
	B3379	P.W.B./for temperature control	220~240V, with triac
③	B1028	Knob	With screw
④	B1084	Power switch	
⑤	B2468	Fuse/125V-5A	100~120V
	B1258	Fuse/250V-3.15A (S)	220~240V
⑥	B2419	Power cord, 3 wired cord & American plug	U.S.A.
	B2421	Power cord, 3 wired cord but no plug	
	B2422	Power cord, 3 wired cord & BS plug	India
	B2424	Power cord, 3 wired cord & European plug	220V KTL, 230V CE
	B2425	Power cord, 3 wired cord & BS plug	230V CE, U.K.
	B2426	Power cord, 3 wired cord & Australian plug	
	B2436	Power cord, 3 wired cord & Chinese plug	China
	B3508	Power cord, 3 wired cord & American plug	
⑦	B2972	Control card	

• Optional Parts

Item No.	Part No.	Part Name	Specifications
①	B1438	FP pick-up	With 1pc. of pick-up wire (S) & (L)
②	B1439	FP pick-up wire (S)	
③	B1440	FP pick-up wire (L)	

1. PARTS LIST / HANDPIECE

NOTE:
Spare or repair parts do not include mounting screws, if they are not listed on the specifications. Screws must be ordered separately.

Item No.	Part No.	Part Name	Specifications
①	B3010	Handle	With screws
②	A1523	Heating element	100 - 120V
	A1524	Heating element	220 - 240V
③	B3009	Mica pipe B	
④	B2995	Quartz glass pipe	For support heating element
⑤	B3008	Mica pipe A	
⑥	B3095	Pipe	
⑦	B3014	Cord assembly	With silicone tube
⑧	B1188	Silicone hose	

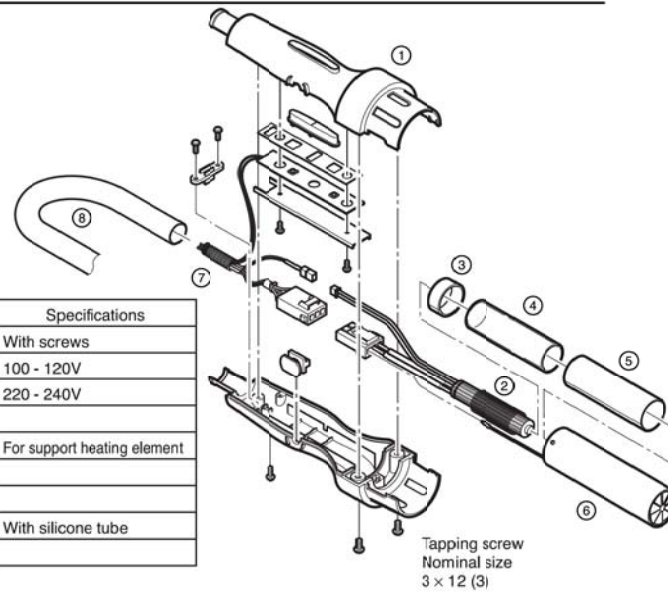

2. MAINTENANCE / INSPECTION

Broken Heater or Sensor

CAUTION
Replacing the heating element is very dangerous. Be sure to turn the power switch OFF and be careful of the following procedure when replacing the heating element.

A Open the handpiece.

1. Move the tube downward. (Figure 1)
2. Remove the three screws holding the handpiece together.
3. Remove the pipe from the protruding portion of the handle.

CAUTION
Quartz glass and heat insulation are inside the pipe. Be careful not to drop or lose these items.

4. Disconnect the heater sensor connector and remove the heater.

B Measure the resistance value.

1. Measure the resistance value (a) of the sensor. The correct value is 0Ω.
2. Measure the resistance value (b) of the heater. The correct values are approximately 33Ω (±10%) (100-120V), 85Ω (±10%) (220-240V) at room temperature. If the resistance value is incorrect, replace the part. (Refer to the instructions included with the replacement part.)

CAUTION
Handle the heating element with care. Never rub the heating element wire!
Insert the handle's projection into the hole in the pipe.

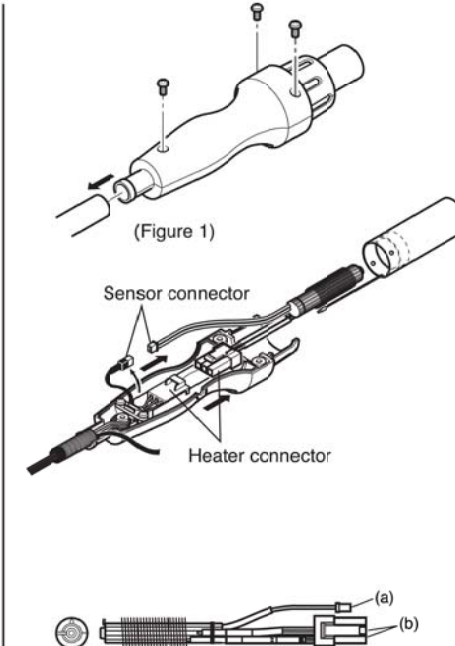

3. TROUBLE SHOOTING GUIDE

WARNING

• Before checking the inside of the HAKKO FR-802 or replacing parts, be sure to disconnect the power plug. Failure to do so may result in electric shock.

- The unit does not operate when the power switch is turned on.
- [S-E] flashes, indicating a sensor error.
- [H-E] flashes, indicating a heater error.

CHECK : Is the fuse blown?
ACTION : Investigate why the fuse blew and then replace the fuse. If the fuse blows again, send the unit in for repair.

CHECK : Is the sensor broken?
ACTION : Measure the resistance value of the sensor. If the resistance value is ∞, replace the parts with the new parts.

CHECK : Is the heater broken?
ACTION : Measure the resistance value of the heater. The correct value are approximately 33Ω (±10%) (100~120V), 85Ω (±10%) (220~240V) at room temperature. If the resistance value is incorrect, replace the part.

4. OPTIONAL NOZZLES

CAUTION
The size in Name/Specification indicates the size of IC package.

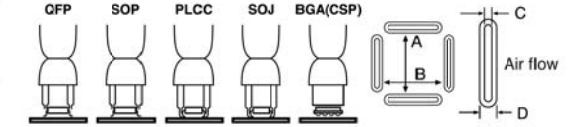

Unit: mm

QFP	SOP	PLCC	SOJ	BGA(CSP)
A1124B Single ø2.5 (0.09)	A1125B QFP 10 × 10 (0.39 × 0.39)	A1126B QFP 14 × 14 (0.55 × 0.55)		
ø2.5 (L.D) (0.09)	A:10.2 (0.4) B:10.2 (0.4) 10 (0.39)	A:15.2 (0.6) B:15.2 (0.6) 15 (0.59)		
A1127B QFP 17.5 × 17.5 (0.68 × 0.68)	A1128B QFP 14 × 20 (0.55 × 0.78)	A1129B QFP 28 × 28 (1.1 × 1.1)	A1130 Single ø4.4 (0.17)	A1131 SOP 4.4 × 10 (0.17 × 0.39)
A:19.2 (0.76) B:19.2 (0.76) 19 (0.75)	A:15.2 (0.6) B:21.2 (0.83) 21 (0.83)	A:29.7 (1.17) B:29.7 (1.17) 29 (1.14)	ø4.4 (L.D) (0.17)	4.8 (0.19)
A1132 SOP 5.6 × 13 (0.22 × 0.51)	A1133 SOP 7.5 × 15 (0.3 × 0.59)	A1134 SOP 7.5 × 18 (0.3 × 0.7)	A1135B PLCC 17.5 × 17.5 (0.68 × 0.68) (44 Pins)	A1136B PLCC 20 × 20 (0.78 × 0.78) (52 Pins)
5.7 (0.22)	7.2 (0.28)	7.2 (0.28)	A:18.5 (0.73) B:18.5 (0.73) 15 (0.59)	A:21 (0.83) B:21 (0.83) 19 (0.75)
A1137B PLCC 25 × 25 (0.98 × 0.98) (68 Pins)	A1138B PLCC 30 × 30 (1.18 × 1.18) (84 Pins)	A1139B PLCC 12.5 × 7.3 (0.49 × 0.29) (18 Pins)	A1140B PLCC 11.5 × 11.5 (0.45 × 0.45) (28 Pins)	A1141B PLCC 11.5 × 14 (0.45 × 0.55) (32 Pins)
A:26 (1.02) B:26 (1.02) 24 (0.94)	A:31 (1.22) B:31 (1.22) 29 (1.14)	6.9 (0.27) 6.9 (0.27) A: 9 (0.35) B:14 (0.55)	A:13 (0.51) B:13 (0.51) 10 (0.39)	A:15 (0.59) B:13 (0.51) 10 (0.39)
A1142B Bent Single 1.5 × 3 (0.06 × 0.12)	A1180B BQFP 17 × 17 (0.67 × 0.67)	A1181B BQFP 19 × 19 (0.75 × 0.75)	A1182B BQFP 24 × 24 (0.94 × 0.94)	A1183 SOJ 15 × 8 (0.59 × 0.31)
45° 1.5 (0.06) (L.D) 3 (0.12) (L.D)	A:18.2 (0.72) B:18.2 (0.72) 13.6 (0.54)	A:19.2 (0.76) B:19.2 (0.76) 16 (0.63)	A:24.2 (0.95) B:24.2 (0.95) 21 (0.83)	8 (0.31)
A1184B SOJ 18 × 8 (0.71 × 0.31)	A1185B TSOL 13 × 10 (0.51 × 0.39)	A1186B TSOL 18 × 10 (0.71 × 0.39)	A1187B TSOL 18.5 × 8 (0.73 × 0.31)	A1188B PLCC 9 × 9 (0.35 × 0.35) (20 Pins)
19 (0.75)	10 (0.39)	11.7 (0.46)	18.5 (0.73)	A:11 (0.43) B:11 (0.43) 10 (0.39)
A1189B PLCC 34 × 34 (1.34 × 1.34) (100 Pins)	A1190 Dual Single 2.5 × 9.5 Pitch (0.09 × 0.37)	A1191 SIP 25L (0.98)	A1192 SIP 50L (1.97)	
A:36.5 (1.44) B:36.5 (1.44) 33.5 (1.32)	ø2.5 (L.D) (0.09)	26 (1.02)	52.5 (2.07)	
A1203B QFP 35 × 35 (1.38 × 1.38)	A1214B SOJ 10 × 26 (0.39 × 1.02)	A1215B QFP 42.5 × 42.5 (1.67 × 1.67)	A1257B SOP 11 × 21 (0.43 × 0.83)	A1258B SOP 7.6 × 12.7 (0.3 × 0.5)
A:35.2 (1.39) B:35.2 (1.39) 31 (1.22)	12 (0.47)	A:42.5 (1.67) B:42.5 (1.67) 40 (1.57)	11.7 (0.46)	8.2 (0.32)
A1259B SOP 13 × 28 (0.51 × 1.1)	A1260B SOP 8.6 × 18 (0.34 × 0.71)	A1261B QFP 20 × 20 (0.78 × 0.78)	A1262B QFP 12 × 12 (0.47 × 0.47)	A1263B QFP 28 × 40 (1.1 × 1.57)
29 (1.14)	19 (0.75)	A:20.2 (0.8) B:20.2 (0.8) 21 (0.83)	A:12.2 (0.48) B:12.2 (0.48) 12 (0.47)	A:27.7 (1.09) B:39.7 (1.56) 39 (1.54)
A1264B QFP 40 × 40 (1.57 × 1.57)	A1265B QFP 32 × 32 (1.26 × 1.26)	A1325 Dual Single ø1.5 × 5-10 (0.06 × 0.2-0.39) Adjustable Pitch		
A:40.2 (1.58) B:40.2 (1.58) 39 (1.54)	A:32.2 (1.27) B:32.2 (1.27) 31 (1.22)	The pitch between the two nozzles is adjustable. 5 (0.2) 10 (0.39)		
A1470 BGA 8 × 8	A1471 BGA 12 × 12	A1472 BGA 13 × 13	A1473 BGA 15 × 15	A1474 BGA 18 × 18
9 (0.35)	13 (0.51)	14 (0.55)	16 (0.63)	19 (0.75)
A1475 BGA 27 × 27	A1476 BGA 35 × 35	A1477 BGA 38 × 38	A1478 BGA 40 × 40	
28 (1.10)	36 (1.42)	39 (1.54)	41 (1.61)	