

HAKKO FE-510

STATIC ELIMINATOR

Instruction Manual

Thank you for purchasing the HAKKO FE-510 Static Eliminator. The HAKKO FE-510 is designed to eliminate the static electricity from a charged object. Please read this manual before operating the HAKKO FE-510. Keep this manual readily accessible for reference.

WARNING

- This product is not specified as an explosion-proof type. Do not use this unit at a location or an atmosphere, in which combustible gas or solvent is handled, or else ignition or explosion may occur.
- A high voltage is applied to the discharge electrode. Do not allow any conductive material, including your finger, any part of your body, wire or any tool to get close to the needle, or an electrical shock accident or a malfunction of the unit may occur.

1. SAFETY PRECAUTIONS

Installation

- Install the product in a location where the power indicator and output signals can be easily checked.
- Do not install the product in any of the following locations, as doing so may cause fire or electrocution.
 - Locations subject to high temperature, or high or low humidity
 - Dusty locations
 - Locations where the air inlet of the fan will be blocked
 - Locations where the product may be exposed to organic solvents such as thinner
 - Locations subject to condensation
 - Locations where the product may be exposed to corrosive gas
 - Locations subject to flames or explosions
 - Locations subject to frequent vibrations
 - Locations subject to sudden changes in temperature or humidity
 - Locations where the product may be exposed to water or oil
- This product emits ozone into an atmosphere. Do not use this product in an enclosed space.

Power Supply

- Make sure to grasp the plug when removing the power cord. Pulling the power cord by the cord may cause it to break, or become damaged and have its core be exposed, which may cause a short circuit, or current leakage and electrocution.
- Make sure to insert the power cord firmly into the power socket. Failure to fully insert the power cord into the socket may cause fire or electrocution.
- Do not insert or remove the power cord with wet hands. Doing so may cause electrocution.
- Do not step on the power cord or place heavy objects on it. Doing so may cause damaged to the cord.
- Make sure to use the power cord included with the product. (INPUT: 100V to 240V 50/60 Hz, OUTPUT: DC 24V)

Maintenance

- Periodically remove the power cord and wipe any dust on the power socket away with a dry cloth. If you leave the power cord inserted in the power socket for a long period in a location with high humidity, dust, or oil, the dust will absorb the humidity, etc., which may result in a short circuit, and cause a fire.
- Make sure to turn the main power of the product OFF before removing the power cord for cleaning.

Handling

- Do not disassemble or modify the product.
- The product may affect medical devices such as hearing aids or pacemakers.
- Take care when using the product, as its internal parts are subject to high voltage.
- Do not insert any foreign objects into the product. Doing so may result in a short circuit or current leakage, and cause fire or electrocution.
- Make sure to connect the earth wire to an appropriate place. Forgetting to connect the earth wire or connecting the earth wire to an inappropriate place may cause electrocution.
- For safety purposes, remove the power cable if you plan on not using the product for an extended period of time.
- If the product emits any abnormal odors or sounds, smoke, or heat, turn OFF the main power immediately, remove the power cord, and contact your point of purchase. Failure to do so may result in fire or short circuit.
- Do not directly touch the electrodes with your hands.
- Do not do anything with the product that is not described in this manual.

HAKKO CORPORATION
 HEAD OFFICE
 4-5, Shiokusa 2-chome, Naniwa-ku, Osaka 556-0024 JAPAN
 TEL: +81-6-6561-3225 FAX: +81-6-6561-8466
 https://www.hakko.com E-mail: sales@hakko.com

OVERSEAS AFFILIATES
 U.S.A.: AMERICAN HAKKO PRODUCTS, INC.
 TEL: (661) 294-0090 FAX: (661) 294-0096
 Toll Free (800) 88-HAKKO
 https://www.HakkoUSA.com E-mail: Support@HakkoUSA.com

Please access the web address below for other distributors.
<https://www.hakko.com>

2. OUTLINE

- This product uses a fan to blow air ionized with the corona discharge of an electrode to eliminate the static electricity in electrically charged materials that are located at a distance.
- The compact and lightweight vertical design enables it to be used anywhere, from a table tops to manufacturing lines.
- The high frequency corona discharge system enables a balanced amount of positive and negative ions to be released for high neutralization performance. The performance of the product also deteriorates little with age, making it low maintenance.
- Includes output signals for abnormal high voltage output (red indicator). When abnormal high voltage occurs in this product, it stops the high voltage output.
- The louver can be easily removed/attached for easy electrode maintenance. This product also includes a safe circuit design that ensures that the high voltage output and fan stop when the louver is removed.
- The amount and angle of the air blowing from the fan is adjustable.

3. PART NAMES

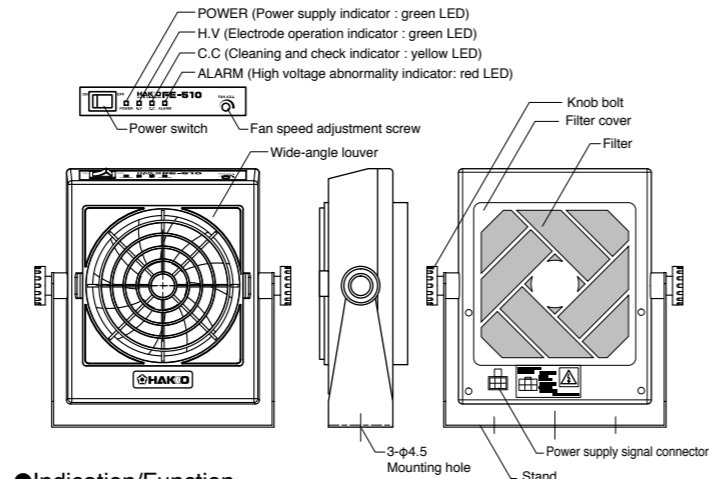

Indication/Function

Name	Indication	Color	Description
Power supply	POWER	Green	Lights up when the power supply is turned ON.
High voltage output	H.V	Green	Lights up when a high voltage output is in a normal operating state.
Cleaning Check	C.C	Yellow	Lights up when a dirt or wear of the electrodes is detected.
High voltage abnormality	ALARM	Red	Light up when abnormal high voltage output occurred, and high voltage output is halted.

4. SPECIFICATIONS

Model Name	HAKKO FE-510
Power-supply voltage	Accessory AC adapter input : 100V to 240V AC, 50/60Hz
AC adapter output	DC 24V
Capacity	10VA
Discharge Method	High frequency AC method
High voltage output	2,000V approx.
Ion balance (NOTE1)	±10V or less
Static charge removal time (NOTE1)	1.5 sec. approx.
High voltage abnormality (ALARM) Output	MOS FET relay output Maximum allowed current : 100mA Applied voltage : DC 30V or less
Cleaning check (C.C) output	MOS FET relay output Maximum allowed current : 100mA Applied voltage : DC 30V or less
Air flow	1.5 to 3.0 m ³ /min
Air flow out angle	Vertically 360° variable (every 10°)
Quantity of produced ozone	0.04 ppm or less (at the center of the fan outlet [150 mm])
Ambient temperature	0 to 40°C
Ambient humidity	15 to 65% (No condensation allowed)
Dimensions : (mm)	150(W) x 182(H) x 50(D) (Main Unit only)
Weight	790g approx. (including stand)
Material	Enclosure : ABS, Discharge electrode : Tungsten, Stand : SECC
Accessories	Instruction manual, AC adapter, Straight louver, Signal output connection wire, Cleaning brush

NOTE1 : Typical value at a distance of 300mm from the center of the fan outlet, at maximum flow rate. (before shipment)

Replacement parts

Part No.	Part Name	Specifications
A1449	Filter	
B3643	Discharge electrode	

5. I/O CIRCUIT DIAGRAM

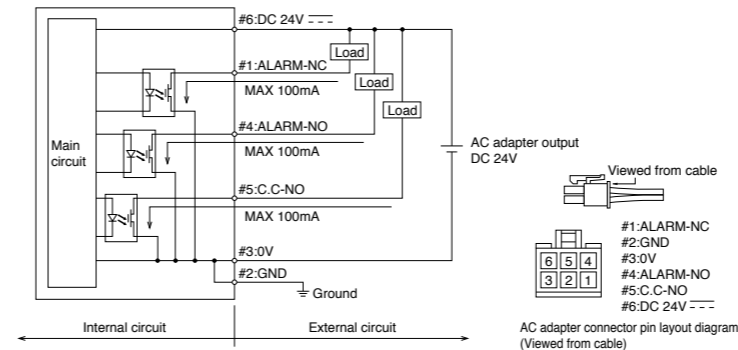

Pin No.	Signal name	I/O	Description
1	ALARM-NC	Output	The signal is turned off when error happens.
2	GND	-	Grounding wire (green)
3	0V	-	Power supply 0V
4	ALARM-NO	Output	The signal is turned off when error happens.
5	C.C-NO	Output	The signal is turned off when lights up when a dirt or wear of the discharge needle is detected.
6	DC 24V	-	Power supply 24V

Note1: GND is connected internally to 0VDC and signal GND.
 Note2: The DC 24V, 0V and GND wire are connected to the connector of the AC adapter before shipment.
 Note3: If the output signals are to be used, connect the wires (accessories) to the connector of the AC adapter.

6. INSTALLATION

- Be sure to turn OFF the power before installing the product.

- Place the product on a level surface. If you want to fix the product to the surface, use the screws already inside the holes, and make sure the product is secured firmly before using it.
- The angle of the main unit may be freely adjusted by loosening the knob bolt. After the adjustment is completed, be sure to tighten the knob bolt again to ensure that the angle of the main unit will stay unchanged.

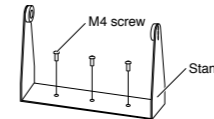

7. WIRING

WARNING

- Be sure to carry out the grounding procedure (according to the class D procedure). Otherwise, an electric shock accident or a malfunction of the unit may occur. In addition, this product may not be able to work up to the full performance.
- Output signals do not incorporate a short-circuit protection circuit. Do not connect the power supply or capacity load directly. Otherwise internal circuit is damaged, and accidents or problems with operation may occur.

Connecting the power supply and output signals

- Connect the grounding lead wire to the grounding terminal located on the backside of the main unit. If it is not securely grounded, the product may not be able to work up to the fullest performance.
- If the output signals are to be used, connect the signal output connection wire (Accessories) to the connector of the AC adapter (Please refer to " 5. I/O circuit diagram"). If no output signals are to be used, these wires do not have to be connected to the connector of the AC adapter.
- Insert the DC 24V output connector of the AC adapter into the power supply signal connector on the backside of the main unit.

Connecting the AC adapter

- Insert the power plug of the AC adapter in an AC (100 to 240V) power outlet.
- Make sure to use the AC adapter included with the product. (INPUT: 100V to 240V 50/60Hz, OUTPUT: DC 24V)

8. OPERATION

- Turn the power switch of the product ON, and green 'POWER' led becomes light up. The electrode becomes charged with high voltage, releases corona discharge, and generates neutralizing ions. At the same time, the fans spin, and blow neutralizing air from the front of the main unit. Charged materials placed in the neutralizing air will be immediately neutralized.
- In accordance with the distance to the charged object, adjust the 'Fan speed adjustment screw' to provide the appropriate amount of air flow. Turn the 'Fan speed adjustment screw' gradually with Phillips screwdriver.
- Press the 'Power Switch' OFF to stop the product.

9. LED STATE AND OUTPUT

	LED state				Output			High-Voltage out
	POWER	H.V	C.C	ALARM	ALARM-NC	ALARM-NO	C.C-NO	
Normal	○	○			ON	OFF	OFF	ON
H.V abnormality	○			○	OFF	ON	OFF	OFF
Cleaning check	○	○	○		ON	OFF	ON	ON
Power OFF					OFF	OFF	OFF	OFF

The internal relay contacts will generate alarm output as above. The terminal block is rated for a maximum current of 200 mA and DC 30V.

10. MAINTENANCE

WARNING

- Before care and maintenance of the product, make sure to turn off the power. Otherwise damage or operating problems may occur.
- The tip of the electrode is sharp, be careful not to touch the discharge needle.

CAUTION

- Clean the discharge electrode periodically even if no cleaning check signal is output. (Once per 2 weeks.)
- When the product is used for long period of time, the discharge needle and the air inlet/ outlet section will get dirty. Clean the discharge needle and the air inlet/ outlet section regularly, otherwise you could not get the desired effect, and errors and accidents may occur.
- The maintenance required depends on the environment of use. As a reference, cleaning both the discharge needle unit and fan filter should be done once per 2 weeks.
- The discharge needle is a part having a product life time. If the charge removal performance is not restored after cleaning the discharge needle, it is recommended to replace the entire discharge needle unit with a new one. The expected life span is seemed to be 20,000 hours in case of natural wear and use.

Cleaning the louver

- Push in the tabs on both sides of the louver, and pull it towards yourself to remove it from the main unit. Clean the louver using the included cleaning brush. If the louver is extremely dirty, wash it with water (or a neutral detergent).
- Re-attach the louver to the main unit after drying it thoroughly.

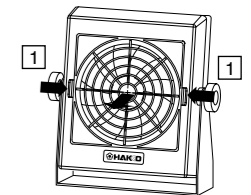

Cleaning the electrodes

- Remove the louver.
- Clean the electrodes using the included cleaning brush. If the electrodes are extremely dirty, it is recommended you add IPA (isopropyl alcohol) to the cleaning brush.

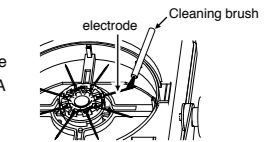

Replacing the discharge electrode

- Remove the louver.
- While securely holding down the main unit in place, remove the discharge electrode by gripping the finger grip at the center of the discharge electrode and turning it in the direction of FREE (clockwise), and releasing the unit.

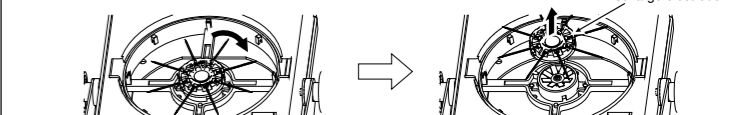

- Prepare a new set of discharge electrode.

- Align the protrusion on the main unit in the section to be engaged with the discharge electrode with the engaging section on the discharge needle unit. Press the discharge electrode into the main unit, so that both units will be engaged with each other. Turn the discharge electrode in the LOCK direction (counterclockwise) until the discharge electrode is securely locked with the main unit.

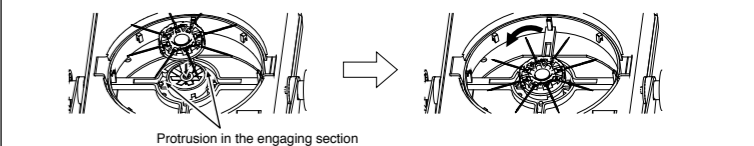

Note1: Turn the discharge electrode until securely locked. The correct installation of the discharge electrode on the main unit is essential for the optimum operation of the product.

Cleaning the filter

- While securely holding down the main unit in position, remove the filter cover. The filter cover may be easily removed by gripping the side of the filter cover and pulling it toward you.
- Clean the soiled or clogged the filter. If the filter is extremely dirty, wash it with water (or a neutral detergent), and dry it thoroughly.
- Re-attach the filter to the main unit.

11. TROUBLESHOOTING

Problem	Main cause	Remedy
The power cannot be supplied to the product.	AC adapter not connected	Check to see if the AC plug is securely inserted into the wall outlet.
	Louver not installed	Check the louver to confirm that it is correctly installed.
High voltage abnormality indicator (ALARM) lights up.	Abnormal discharge	Check that the discharge needle is free from conductive materials.
	Grounding wire not connected	Check that the grounding wire is securely grounded.
	Internal circuit is broken	Turn off the power, and then turn the power back on.
Cleaning check indicator (C.C) lights up.	Discharge electrode not installed	Check that the discharge electrode to confirm that it is correctly installed.
	Dirt on electrodes	C.C indicator remains light up even after the electrode has been cleaned, clean the area around the electrode is dirty.
	Wear on electrodes	Replace the entire discharge electrode with a new one.
	Abnormal discharge	Check that the discharge electrode is free from conductive materials.
	High humidity or condensation	Do not use it in high humidity or condensation environment.
Grounding wire not connected	Check that the grounding wire is securely grounded.	