

1. PARTS LIST

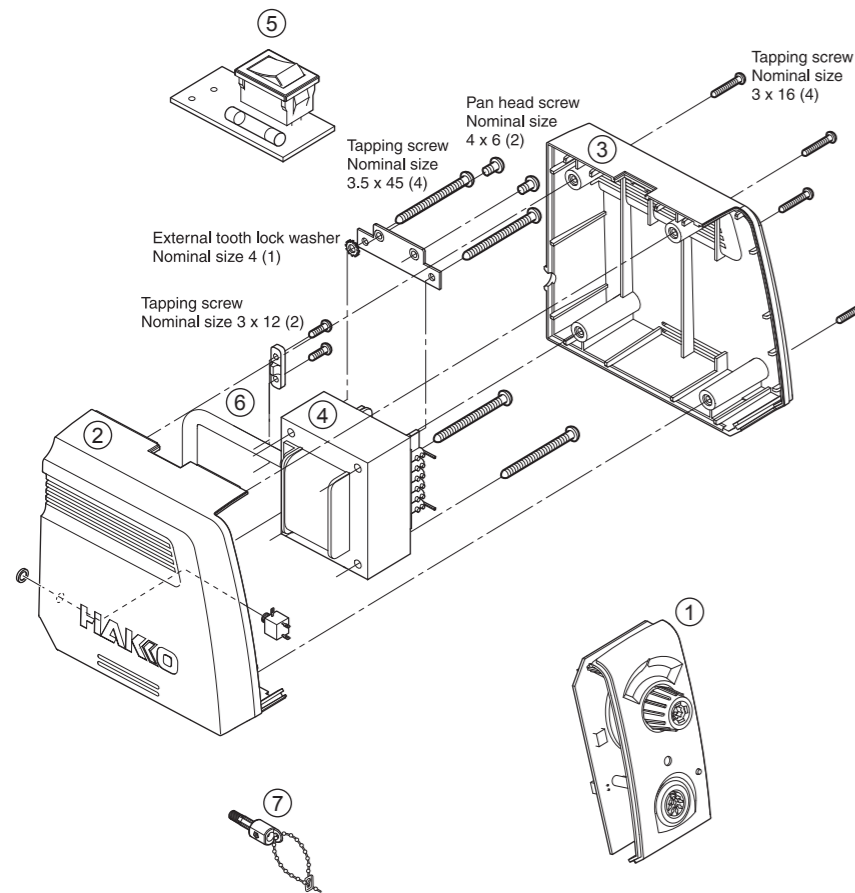

● HAKKO FX-950 Station

Item No.	Part No.	Part Name	Specifications
①	B3440	Front panel assy.	With knob and display window
②	B3310	Case/Left	With rubber feet
③	B3311	Case/Right	With rubber feet
④	B3312	Transformer	100 V
	B3313	Transformer	110 V
	B3314	Transformer	120 V
	B3315	Transformer	220 V
	B3316	Transformer	230 V
	B3317	Transformer	240 V

Item No.	Part No.	Part Name	Specifications	
⑤	B3319	PWB/Power Switch	100 - 120 V / With Fuse	
	B3320	PWB/Power Switch	220 - 240 V / With Fuse	
⑥	B1319	Power code, 3-wire cord & American plug	120V USA	
	B1318	Power code, 3-wire cord but no plug		
	B2098	Power code, 3-wire cord & BS plug		
	B3346	Power code, 3-wire cord & European plug	KTL, CE	
	B3347	Power code, 3-wire cord & BS plug	CE	
	B2042	Power code, 3-wire cord & Australian plug		
	B2486	Power code, 3-wire cord & Chinese plug		
	B3504	Power code, 3-wire cord & American plug		
	⑦	B3308	Lock key	

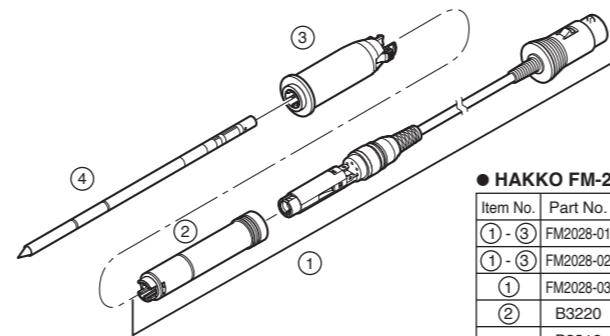

● HAKKO FM-2028

Item No.	Part No.	Part Name	Specifications
① - ③	FM2028-01	HAKKO FM-2028	③ is yellow
① - ③	FM2028-02	HAKKO FM-2028	③ is blue
①	FM2028-03	Connector assembly	
②	B3220	Connector cover	
	B3216	Sleeve assembly	Yellow
	B3217	Sleeve assembly	Orange
	B3218	Sleeve assembly	Blue
④	B3219	Sleeve assembly	Green
		Tip	See back page.
⑤	B2300	Heat resistant pad	

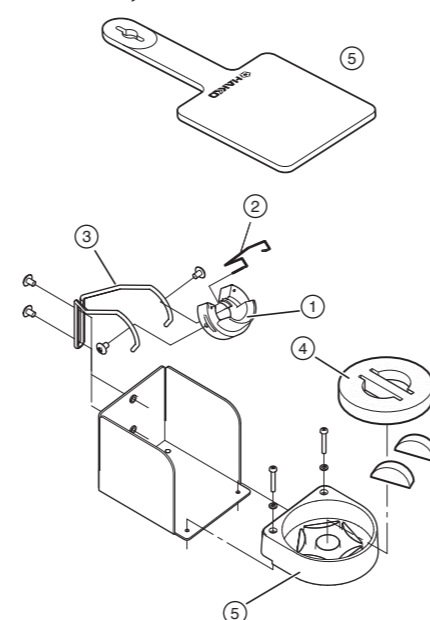

● Iron Holder

Item No.	Part No.	Part Name	Specifications
① - ⑤	FH101-02	Iron holder	With cleaning sponge

● Iron Holder Parts

Item No.	Part No.	Part Name	Specifications
①	B3001	Iron receptacle	Yellow, with screws
②	B2791	Tip fixing spring	
③	B3248	Holder for iron receptacle	
④	A1519	Cleaning sponge	
⑤	B3249	Cleaner base	With rubber feet

● Options

Part No.	Part Name	Specifications
B3253	Connecting cable	
FH200-01	Iron holder	With cleaning wire
FH200-02	Iron holder	With cleaning sponge
B2756	Tip tray	

2. MAINTENANCE/CHECKING PROCEDURE

Performing proper and periodical maintenance extends the products life and contributes to use it always in a good condition. Efficient soldering depends upon the temperature, the quality and quantity of the solder and flux. Apply the following service procedure as dictated by the conditions of the usage.

⚠ WARNING

Since the soldering iron can reach a very high temperature, please work carefully. Except the case especially indicated, always turn the power switch OFF and disconnect the power plug before performing any maintenance procedure.

● Tip maintenance

1. Tip temperature

High temperatures shorten tip life and may cause thermal shock to components. Always use the lowest possible temperature when soldering. The excellent thermal recovery characteristics of the HAKKO FX-950 ensure effective soldering at low temperatures.

2. Cleaning

Always clean the soldering tip before use, to remove any residual solder or flux adhering to it. Use a clean and moist cleaning sponge No. A1519 (provided with the HAKKO FX-950) or the HAKKO 599B tip cleaner. Contaminants on the tip have many deleterious effects, including reduced heat conductivity, which contribute to poor soldering performance.

3. After use

Always clean the tip and coat it with fresh solder after use. This guards against oxidation.

4. When the unit is not being used.

Never allow the unit to idle at a high temperature for extended periods. This will allow the tip to become oxidized. Turn the power switch OFF. If it is to be out of service for several hours, it is advisable to pull the power plug as well.

5. Tip maintenance

This procedure, if followed daily, will materially add to tip life.

- Set the temperature to 250°C. (482°F)
- When the temperature stabilizes, clean the tip (see 2, above) and check the condition of the tip. If the tip is badly worn or deformed, replace it.
- If the solder plated part of the tip is covered with black oxide, apply fresh solder, containing flux, and clean the tip again. Repeat until all the oxide is removed, then coat the tip with fresh solder.
- Turn the power OFF and remove the tip, using the heat resistant pad. Set the tip aside to cool.
- Remaining oxides, such as the yellow discoloration on the tip shaft, can be removed with isopropyl alcohol.

⚠ CAUTION
NEVER file the tip to remove oxides!

3. CHECKING PROCEDURE

⚠ WARNING

Unless otherwise directed, carry out these procedures with the power switch OFF and the power UNPLUGGED.

● Check for a broken heater or sensor

- Check for a broken heater or sensor

Measure the resistance across this position.

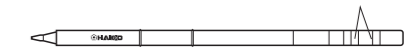

Verify the electrical integrity of the heater and sensor. Measure the resistance of the heater and sensor while at room temperature (15 to 25°C.; 59 to 77°F.). It should be 8Ω ±10%. If the resistance exceeds these limits, replace the tip.

- Unplug the connection cord from the station.
- Measure the resistance value between Pin 2 and the tip.
- If the value exceeds 2Ω (at room temperature), perform the tip maintenance described on section 2, maintenance for the tip. If the value still does not decrease, check the connection cord for breakage.

● Check the grounding line

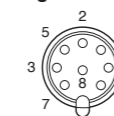

● Checking the connection cord for breakage

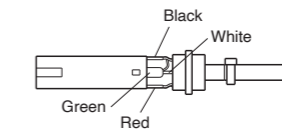

- Remove the soldering tip and the sleeve assembly.
- Turn the front piece of the HAKKO FM-2028 counterclockwise and remove the cover.
- Measure the resistance values between the connector and the lead wires at the socket as follows:

Pin 1 - Red Pin 2 - Green
Pin 3 - Black Pin 5 - White

If any value exceeds 0Ω or is ∞, replace the HAKKO FM-2028.

● Replacing the fuse

- Disassemble the HAKKO FX-950.
- Remove the solder from the fuse and then solder in a new fuse (see the illustration of "PARTS LIST").
- Reassemble the HAKKO FX-950.

4. TROUBLE SHOOTING GUIDE

⚠ WARNING

Before checking the inside of the HAKKO FX-950 or replacing parts, be sure to disconnect the power plug. Failure to do so may result in electric shock.

● The unit does not operate when the power switch is turned on.

CHECK : Is the power cord and/or the connection plug disconnected?

ACTION : Connect it.

CHECK : Is the fuse blown?

ACTION : Investigate why the fuse blew and then replace the fuse. If the cause can not be determined, replace the fuse. If the fuse blows again, send the unit in for repair.

● The tip does not heat up.

- Sensor error
- The lamp flashes red rapidly (about once every 0.2 second).

CHECK : Is the tip inserted properly?

ACTION : Insert the tip completely.

CHECK : Is the connection cord and/or the heater/sensor broken?

ACTION : See the appropriate section of this manual regarding how to check the connection cord and/or the heater/sensor for breakage.

● Solder does not wet the tip.

CHECK : Is the tip temperature too high?

ACTION : Set the appropriate temperature.

CHECK : Is the tip contaminated with oxide?

ACTION : Remove the oxide (see "Tip maintenance" on section 2).

● The tip temperature is too high.

CHECK : Is the connection cord broken?

ACTION : See "Checking the connection cord for breakage" on section 2.

CHECK : Is the entered offset value correct?

ACTION : Enter the correct value.

● The tip temperature is too low.

CHECK : Is the tip contaminated with oxide?

ACTION : Remove the oxide (see "Tip maintenance" on section 2).

CHECK : Is the entered offset value correct?

ACTION : Enter the correct value.

● Soldering iron error

- The lamp flashes red slowly (about once every 0.5 second).

● Heater terminal short circuit error

- The lamp flashes alternately red and green rapidly (about once every 0.2 second).

● Though the soldering iron is placed on the iron holder, the sleep function is not activated.

CHECK : Is incorrect soldering iron connected?

ACTION : Connect the HAKKO FM-2028 soldering iron.

CHECK : Is the tip a genuine tip for the HAKKO FM-2028 (T15 tip)?

ACTION : After turning the power switch OFF, insert a genuine tip for the HAKKO FM-2028 (T15 tip) and then turn the power switch ON again.

CHECK : Check that the connecting cable is inserted firmly into the jack.

ACTION : Turn off the power switch and insert the connecting cable again.

TIP STYLES

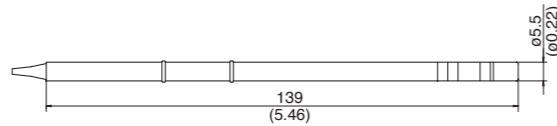

Unit: mm (in.)

SHAPE B

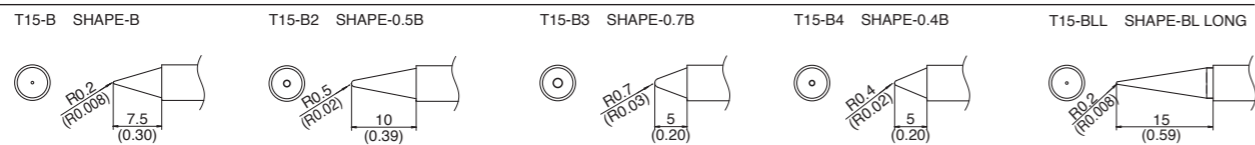

SHAPE BC

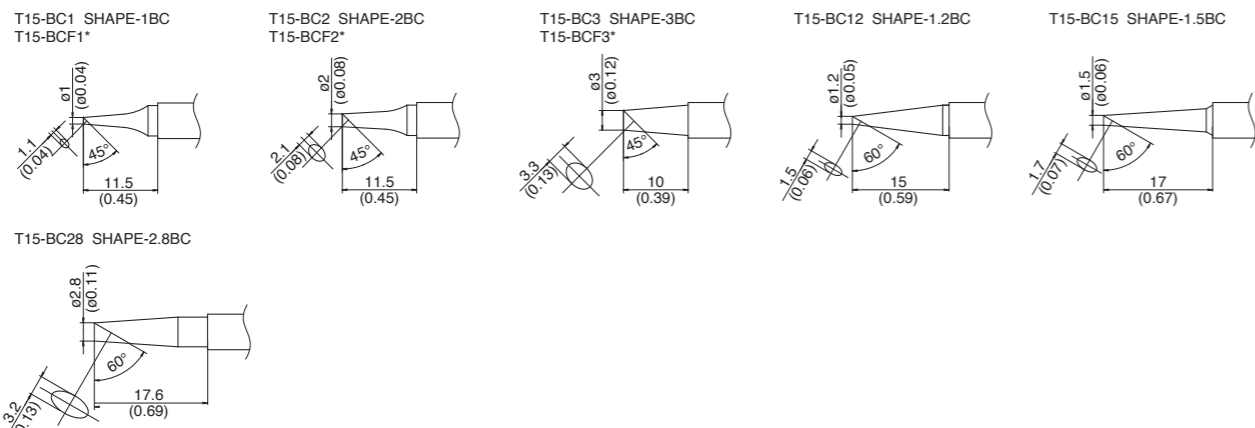

SHAPE C

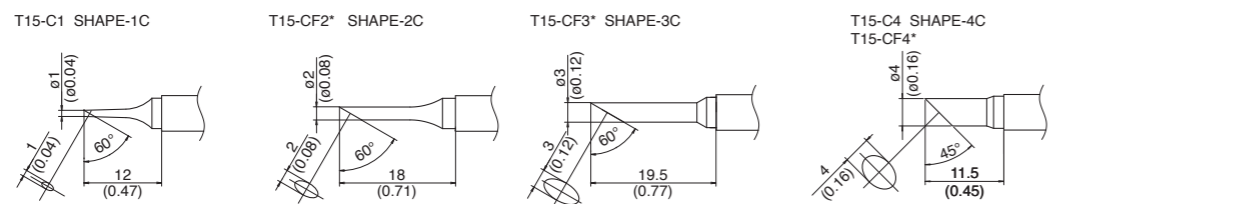

SHAPE D

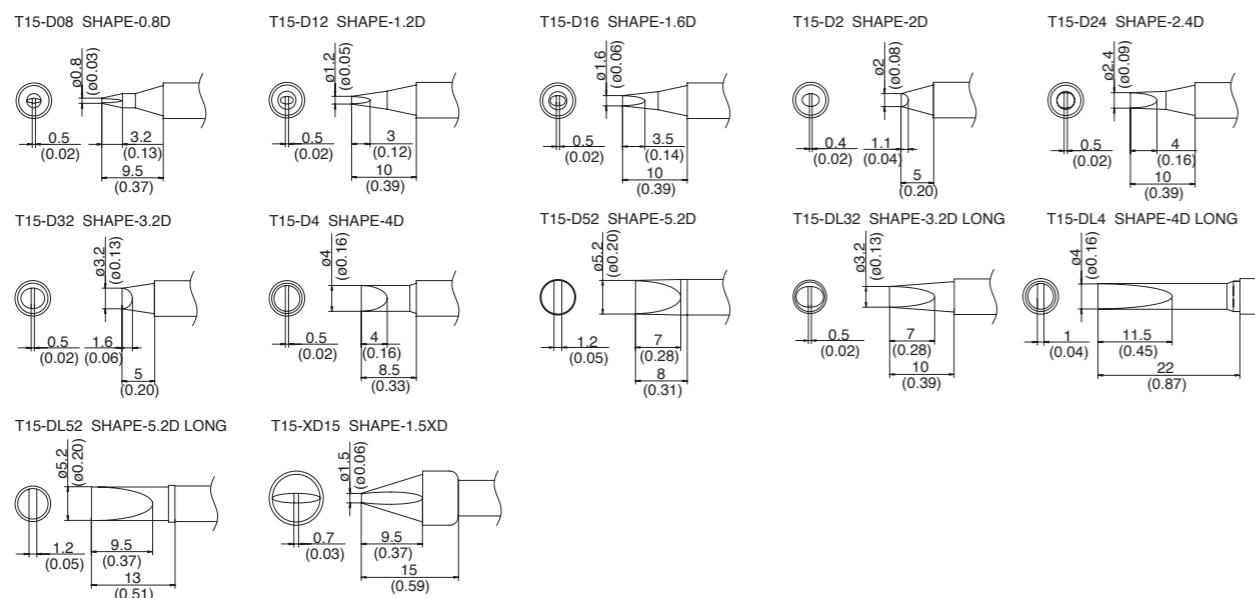

SHAPE I

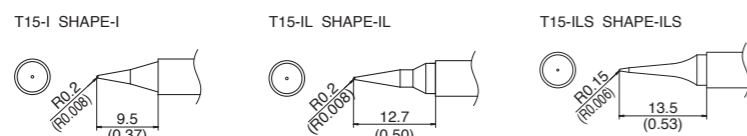

SHAPE J

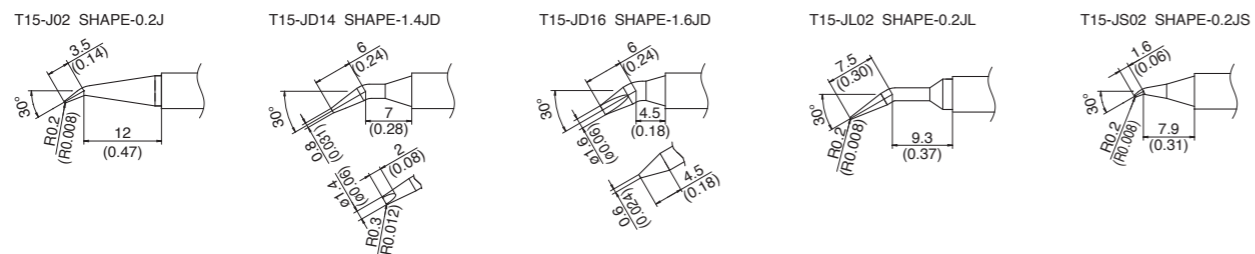

SHAPE K

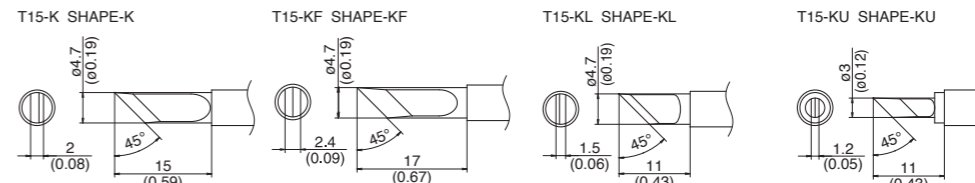

SHAPE R

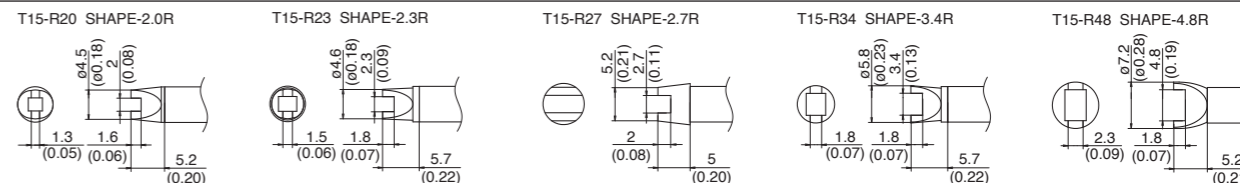

SHAPE SB

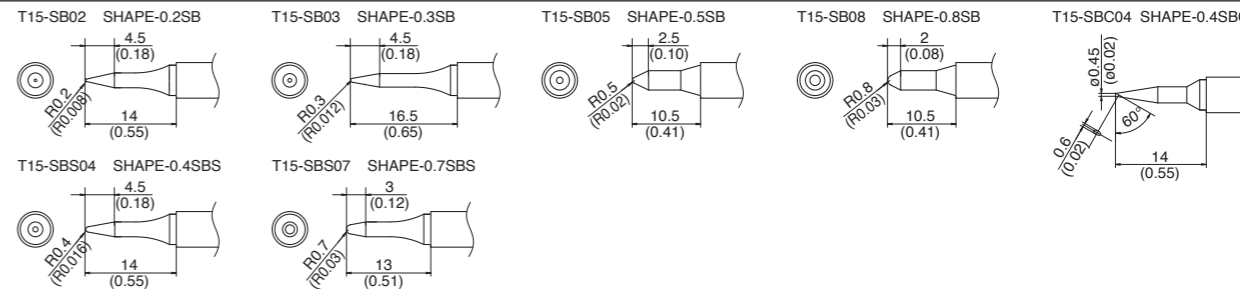

TUNNEL

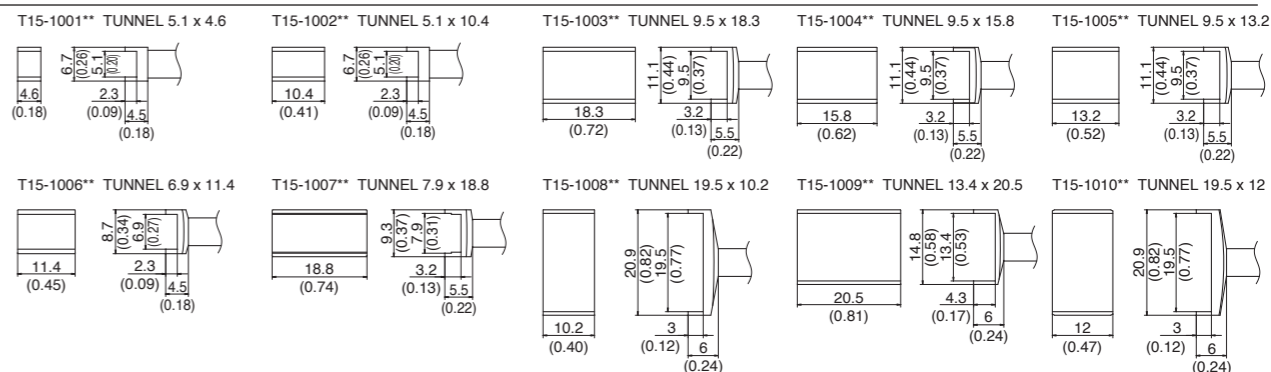

QUAD

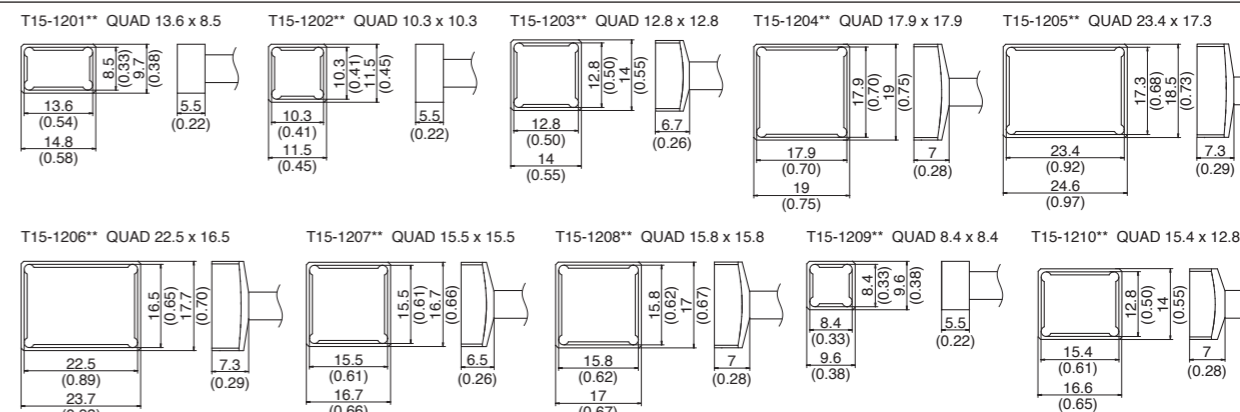

SPATULA

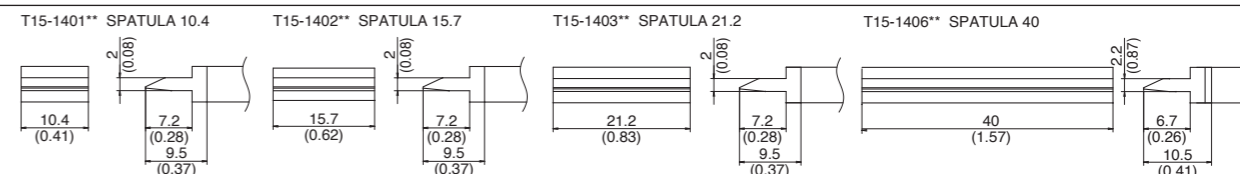

SPECIAL APPLICATIONS TYPE

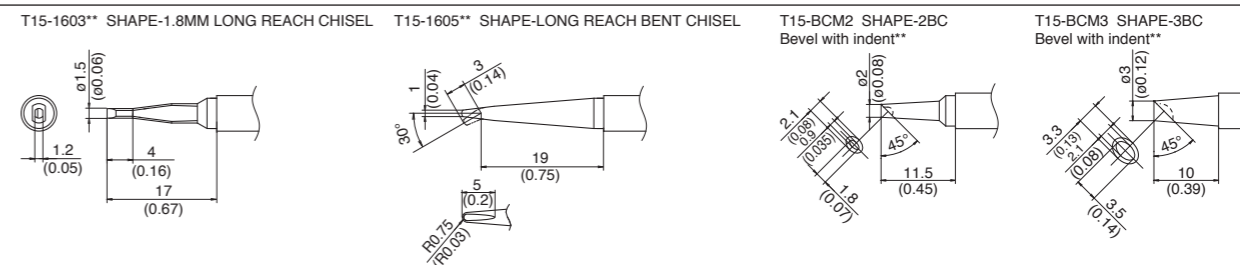

* Tinned on the soldering surface only.

** The iron tips marked with double asterisks (**) have a temperature accuracy of $\pm 25^{\circ}\text{C}$ ($\pm 45^{\circ}\text{F}$), when used with the default offset. Others have a temperature accuracy of $\pm 15^{\circ}\text{C}$ ($\pm 27^{\circ}\text{F}$), when used with the default offset.