



HAKKO 927

SOLDERING STATION

INSTRUCTION MANUAL

Please read this instruction manual thoroughly before operating the HAKKO 927

Specification

● Station

Power Consumption	AC100, 110, 120, 220, 230, 240V ± 10%, 60W
Output Voltage	AC24V
Temperature	200~480°C / 392~899° F
Temperature Control	±0.5°C (±0.9°F) <small>Control accuracy of setting at idling temperature.</small>
Outer Dimensions	110(W) × 81(H) × 190(D)mm 4.3" × 3.2" × 7.5" (Without Cord.)
Weight	Approx. 1.6Kgs. (3.5lb)

● Iron

Part No.	900S	900M	900L
Part No.	900S-ESD	900M-ESD	900L-ESD
Power Consumption	AC24V 50W		
Insulation Resistance	Over 300MΩ at 400°C / 750° F		
Leak Voltage	under 0.6mV		
Heating Element	Ceramic Heater		
Cord Asse'y	5 wire burn-proof silicon cord, 1.2m (4ft.)		
Connecting Plug	5 pin inter-lock system		
Length (w/o cord)	176mm (7")	190mm (7.5")	210mm (8.3")
Weight	25g(0.061lb)	45g(0.1lb)	55g(0.12lb)
Grip Material	Heat Resisting Plastic		

Conditions of Measurement

● Tip Temperature

The tip temperature was measured using HAKKO 191 thermometer.

● Insulation Resistance

The insulation resistance was measured between the tip and the lead of the Heating Element using a 500V DC insulation resistance meter.

Caution : The insulation resistance cannot be measured between the tip and the power plug as the transformer between the secondary part (Heating Element) and the primary part acts as an insulator.

※The specification written here may be subject to change without notice.

Parts Name

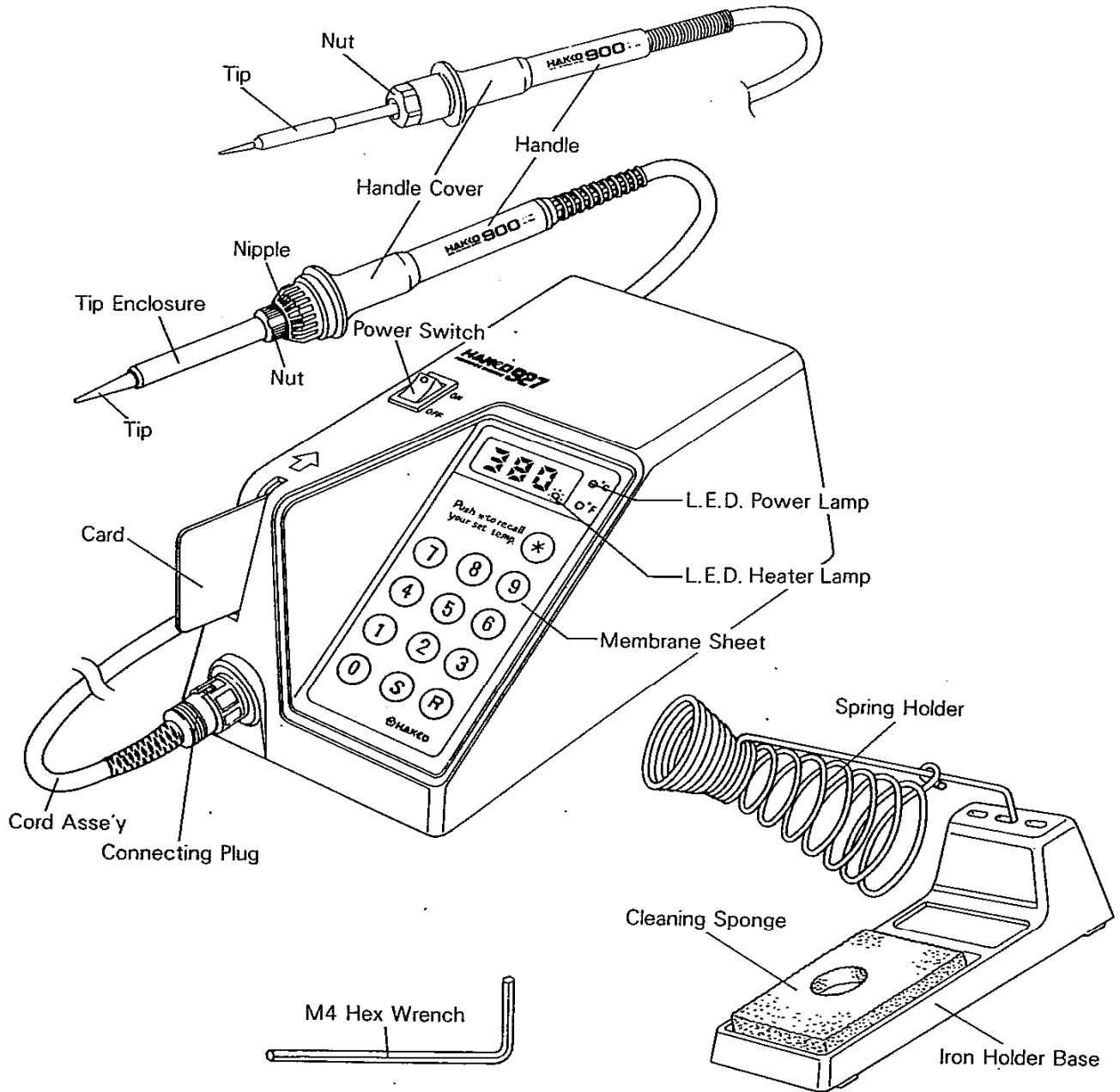

● Accessories

- HAKKO 631
- M4 Hex Wrench
- Card

HAKKO 631

- Iron Holder Base
- Spring Holder
- Cleaning Sponge

Operating Instructions

- 1 . Insert the Spring Holder into the hole at the Iron Holder Base.
- 2 . Place the Cleaning Sponge in the sponge receptacle and dampen it with clean water.
Note : Specially coated soldering tips may be damaged if they are cleaned on a dry sponge.

- 3 . Insert the 5-pin Connecting Plug into the Receptacle on the Station. Lock the plug by turning the plug's outer ring clockwise.

Warning : To prevent damage to the Control PCB inside the Station, be sure to turn the power off before connecting or disconnecting the Connecting plug.

- 4 . Plug the Station into a properly grounded AC outlet.
- 5 . Insert a card.

Note : The HAKKO 927 has a factory-adjusted temperature setting of 400°C/750° F . Therefore, if the desired tip temperature is 400°C/750° F it is not necessary to insert the card — simply wait until the LED Heater Lamp begins to blink, then start soldering.

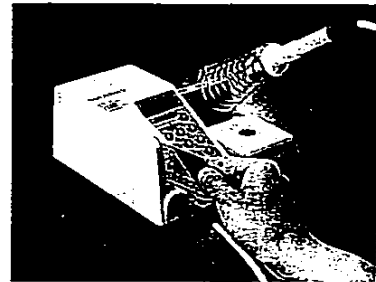

- 6 . To change the tip temperature, first insert the card. This will cause the Heating Element and the Digital Display to turn off. Using the pushbutton, set the desired tip temperature. After confirming the temperature on the Digital Display, press the (S) (Set) button to set the temperature. The LED Heater Lamp will soon turn on and the Heating Element will begin warming up. When the tip reaches the desired temperature, the LED Heater Lamp will begin blinking. To recall the set temperature on the Digital Display, press and hold down the (*) button.
- 7 . Should you make a mistake in setting the temperature, press the (R) (Reset) button. The Digital Display and the Heating Element will both turn off. Simply reenter the desired tip temperature and press the (S) button.
Note : The Heating Element will not warm up until the (S) button is pressed.
- 8 . When the desired tip temperature has been set, remove the card. Once the card is removed, the temperature cannot be changed without reinserting the card.
The tip temperature value is now stored in Station's built-in computer memory, allowing you to turn the power off and on without having to reset the temperature each time. To reset the temperature, simply reinsert the card, with the HAKKO 927, supervisors can now accurately and safely monitor tip temperatures.
- 9 . The card can also be left inserted in the Station, allowing the HAKKO 927 to be used as a general soldering station.
 - 1) Power switch on.

- 2) Insert the card.
- 3) Set the desired tip temperature and press the $\text{\textcircled{S}}$ button.
- 4) To change the set temperature, press the $\text{\textcircled{R}}$ button, enter the desired temperature, and press the $\text{\textcircled{S}}$ button.
- 5) When the power is turned off with the card still inserted, then turned on again, the previously set tip temperature (stored in memory) will be indicated on the Digital Display. To change the set temperature, refer to items 4 and 5 above.

10. LED Heater Lamp

On (lit) Heating Element On

Blinking Heating Element On and Off

Off (unlit)..... Heating Element Off

* After the temperature was set, the $\text{\textcircled{S}}$ button was pressed again.

* The tip temperature is higher than the desired temperature.

When the temperature drops to the desired temperature, the LED Heater Lamp will begin blinking.

Digital Display

EEE * Sensor malfunction

* Overheated tip

LED Heater Lamp lit, but tip temperature

does not increase after 5 seconds Heating Element malfunction

11. Using the Pushbutton Key Pad

In general, the pushbuttons on the key pad can only be operated while the card is inserted in the Station.

Exceptions

* The $\text{\textcircled{*}}$ button can be operated at any time.

* After the Digital Display indicated 3 digits, the $\text{\textcircled{R}}$ and $\text{\textcircled{S}}$ buttons can be operated even with the card removed from the Station.

1) The tip temperature cannot be set below 100°C/200°F or above 480°C/899°F.

2) After setting temperature, the $\text{\textcircled{S}}$ button must be pressed in order to store the temperature in memory and begin warming up the Heating Element.









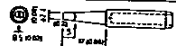
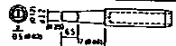

3) The $\text{\textcircled{R}}$ button can be operated during and after setting of the temperature and after pressing the $\text{\textcircled{S}}$ button. (After pressing the $\text{\textcircled{S}}$ button, the $\text{\textcircled{R}}$ can only be operated with the card inserted in the Station.)

4) The Digital Display normally shows the tip temperature. To recall the set temperature, press the $\text{\textcircled{*}}$ button.

Precautions

- 1 . Never strike the Soldering Iron against the workbench or other solid surface as the ceramic Heating Element is very fragile and cannot withstand sharp blows.
- 2 . Before using the Soldering Iron, make sure the Nut securing the Tip Enclosure Assembly is properly tightened.
- 3) When replacing the Heating Element, first unscrew the Nut, then the Nipple. After replacing the Heating Element, first screw on the Nipple, then the Nut. (Disassembly/assembly in the reverse order may result in damage to the Heating Element.)
- 4) Always remove excess solder from the Tip prior to soldering.
- 5) HAKKO recommends using a heavier tip with the 900L for heavy-duty soldering, and a fine tip with the 900S for micro soldering.
- 6) HAKKO also recommends using a lower-than-usual tip temperature. The HAKKO 900's superfast warm up time and faster thermal recovery permits high quality soldering at lower tip temperatures.

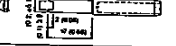
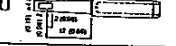
Replacement Tip

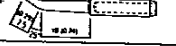
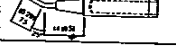
900M	
900M-T-1.6D	 0 (480°C, 899°F)
900M-T-2.4D	 0 (480°C, 899°F)
900M-T-3.2D	 0 (480°C, 899°F)
900M-T-B	 0 (480°C, 899°F)
900M-T-LB	 -10°C, -18°F (470°C, 881°F)
900M-T-1C 900M-T-1CF*	 0 (480°C, 899°F)
900M-T-2C 900M-T-2CF*	 0 (480°C, 899°F)
900M-T-3C 900M-T-3CF*	 0 (480°C, 899°F)
900M-T-4C 900M-T-4CF*	 0 (480°C, 899°F)
900M-T-K	 +30°C, +54°F (510°C, 953°F)
900M-T-R	 0 (480°C, 899°F)
900M-T-RT	 0 (480°C, 899°F)
900M-T-I	 -10°C, -18°F (470°C, 881°F)
900M-T-H	 -20°C, -36°F (460°C, 863°F)
900M-T-1.8H	 -10°C, -18°F (470°C, 881°F)

● 900M Tip Out Diam ϕ 6.5

900S



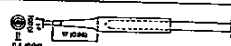
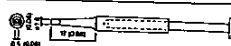
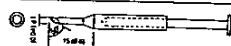
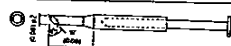
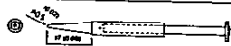
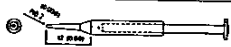



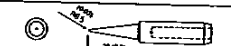
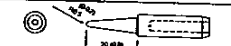

For micro soldering HAKKO recommends The 900S Iron with fine tips.

900S-T-1.2D	 0 (480°C, 899°F)
900S-T-1.6D	 0 (480°C, 899°F)
900S-T-1C	 0 (480°C, 899°F)
900S-T-2C	 0 (480°C, 899°F)
900S-T-B	 0 (480°C, 899°F)
900S-T-I	 0 (480°C, 899°F)

● 900S Tip Out Diam ϕ 5.8

900L

For heavy duty soldering HAKKO recommends The 900L Iron with heavier tips.

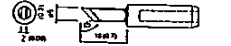
900L-T-B	 0 (480°C, 899°F)
900L-T-2B	 0 (480°C, 899°F)
900L-T-2.4D	 0 (480°C, 899°F)
900L-T-3.2D	 0 (480°C, 899°F)
900L-T-2C 900L-T-2CF*	 -20°C, -36°F (460°C, 863°F)
900L-T-3C 900L-T-3CF*	 0 (480°C, 899°F)
900L-T-4C 900L-T-4CF*	 0 (480°C, 899°F)
900L-T-5C 900L-T-5CF*	 0 (480°C, 899°F)
900L-T-I	 -20°C, -36°F (460°C, 863°F)
900L-T-K	 +20°C, +36°F (500°C, 935°F)

● 900L Tip Out Diam ϕ 8.5

★ -These tips are tinned flat only.

● Caution

- 1) Use exclusive tips for HAKKO 900 only.
- 2) The set temperature should be adjusted according to the tip configuration.
If required, adjust the temperature with "CAL" potentiometer on bottom of station when changing tip configurations.
The temperature is increased by turning "CAL" clockwise.
- 3) When using the Soldering Iron continuously loosen Tip and remove oxide once a week.
This helps prevent seizure and reduction of Tip temperature.

- 4) Tin the tip daily as follows :

1. Clean the Tip.
2. Set the temperature at 200°C (392°F).
3. Melt the solder gradually at the tip.

■ The tip temperature may vary depending on the figure. Refer to the chart for the correct adjustment.

(Example)

When using 900M-T-H Tip at 400°C,
The gap between standard tip is -20°C.
Set the temp at 420°C.

Trouble Shooting Guide

If the Soldering Iron doesn't heat-up or uncontrollable and Tip becomes over-heat when the Power Switch on, please check as follows ;

CAUTION : Disconnect the plug before checking.

(Case 1) L.E.D. Power Lamp doesn't light up.

- Check Fuse ... Replace Fuse if necessary as follows,
 In put AC220V~240V ; AC250V-1A Fuse
 In put AC100V~120V ; AC125V-2A Fuse
- Check Power Cord ... Repair or replace with new one.

(Case 2) L.E.D. Power Lamp lights up.

Confirm whether the Connecting Plug is connected correctly.
 Disconnect the Connecting Plug and measure the resistance value between pins of Cord Asse'y's Plug as follows ;

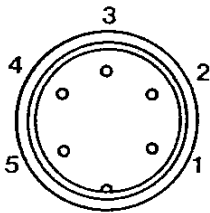

a	Between pin 4 & pin 5 (Heating Element)	2.5~3.5 ohm (Normal)
b	Between pin 1 & pin 2 (Sensor)	43 ~ 58 ohm (Normal)
c	Between pin 3 & Tip (Grounding)	Under 10 ohm

(1) If the value of "a" & "b" is different from above value, replace the Heating Element (Sensor) or Cord Asse'y.

(2) On HAKKO 900M, 900L.

If the value of "c" - between pin 3 and tip (Grounding) is over above value, remove the oxidization film by rubbing points shown as under with sand-paper or steel wool.

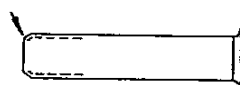

Tip Enclosure

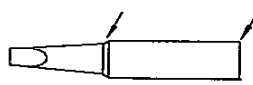

Tip

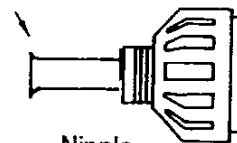

Nipple

On HAKKO 900S.

If the value of "c" - between pin 3 and tip (Grounding) is over above value, check the Cord Asse'y and replace it.

- If the problem remains unsolved after check in the Soldering Iron, the Station may have a problem.

Please contact your nearest HAKKO representative.

Replacing the Heating Element

● 900S Soldering Iron

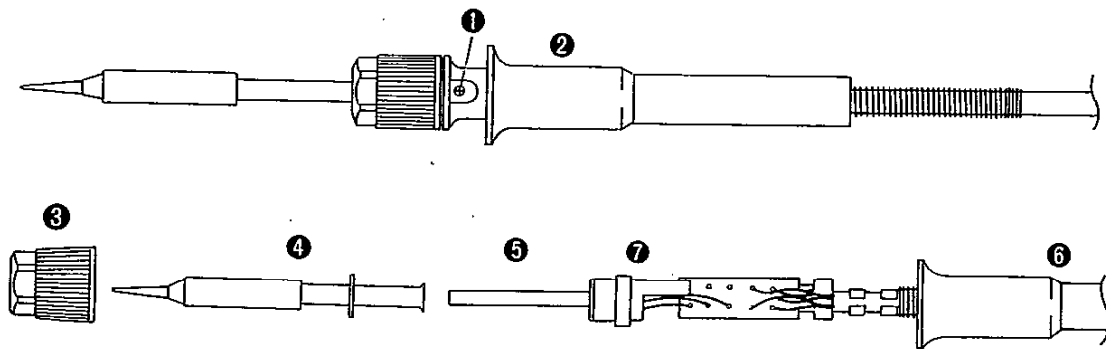

- 1 . Slide the Handle Cover ② toward the Power Cord and remove the Screw ① securing the Heating Element.
- 2 . Turn the Nut ③ counterclockwise and remove it.
- 3 . Remove the Tip ④ .
- 4 . Pull both the Heating Element ⑤ & the Power Cord toward the tip of the Iron and out of the Handle ⑥
- 5 . Measure the resistance values at the Sensor and the Terminal. Should the resistance value be correct, the Cord Asse'y will have to be changed as it is disconnected.

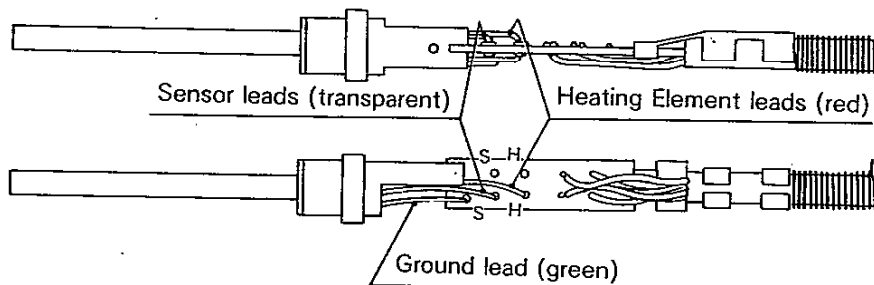

- 6 . Unsolder the Heating Element leads, Sensor leads and Ground lead. Remove the Heating Element and the Heating Element Holder ⑦ . Be careful not to damage the leads with soldering iron.
 - 7 . Solder the new Heating Element and resolder the Ground lead. Resolder the two Sensor leads (transparent) and the two Heating Element leads (red). Be careful not to damage the leads.
- Note : There is no polarity between leads of the same color.
- 8 . Pull on the Power Cord to reset the Heating Element in the Handle. Align the holes in the Heating Element Holder ⑦ with the holes in the Handle ⑥ .
 - 9 . Secure the Heating Element with the Screw ①
 - 10 . Insert the Heating Element ⑤ into the Tip and secure it with the Nut ③ .
 - 11 . Slide back the Handle Cover ② in its place.

● 900M·900L Soldering Iron

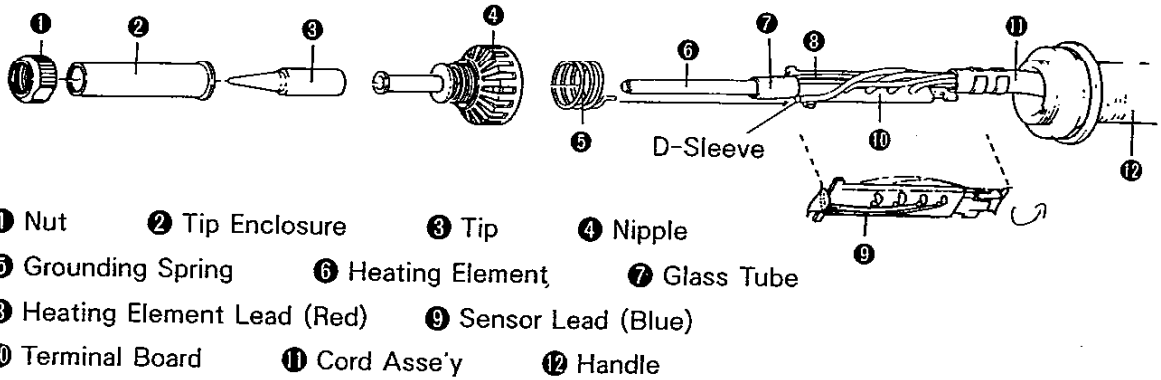

- 1) Turn the Nut ① counterclockwise and remove the Tip Enclosure ②, the Tip ③.
- 2) Turn the Nipple ④ counterclockwise and remove it from Iron.
- 3) Pull both the Heating Element ⑥ and the Cord Asse'y ⑪ out of the Handle ⑫ (toward the tip of the Iron).
- 4) Pull the Grounding Spring ⑤ out of the D-Sleeve.
- 5) Measure the resistance value at the Sensor and Heating Element of the Terminal.

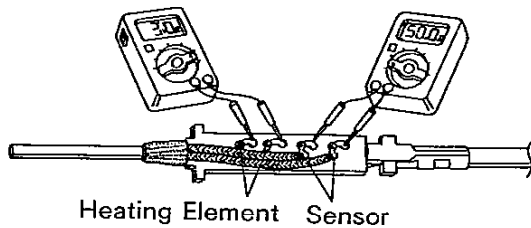

Resistance Value of Heating Element	2.5~3.5Ω
Resistance Value of Sensor	43~58Ω

Measure in normal condition.

- If the resistance value is not normal, replace the Heating Element.
 - If the resistance value is normal, the Cord Asse'y may be broken.
- 6) Desolder the Heating Element Leads.
 - In the above Item 5 & 6, be careful not to damage the leads with soldering iron.

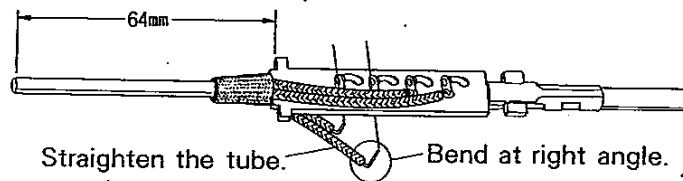

- 7) Solder the new Heating Element. Solder two Sensor Leads (blue) and Heating Element Leads (red) on the Terminal Board ⑩ as above drawing.
- There is no polarity between leads of the same color.
- 8) Insert the Grounding Spring into the Heating Element. And connect the Grounding Spring and D-sleeve on the side of the Heating Element Leads.
- 9) Pull the Power Cord and fix the Heating Element in the Handle to prevent rolling.
- 10) Turn the Nipple and secure the Handle.
- 11) Replace the Nipple ④, the Tip ③, the Tip Enclosure ② and secure the Nut ①.

Recalibrating of Iron Temperature

The Soldering Iron has been tested and calibrated in the factory, however, recalibration may be necessary in the following cases.

- * After replacing the Soldering Iron with a larger or smaller iron, i.e., replacing an 900M iron with an 900S or 900L iron.
- * After replacing the Heating Element.
- * After replacing the Tip with one of a different type.

1. Test Mode

1. Allow the HAKKO 927 to cool to room temperature for one hour, then connect the Soldering Iron.
2. Press buttons ④ and ⑤ simultaneously and turn the Power Switch on. (Do not use the Card to turn the Station on.) This turns the Heating Element off. The Digital Display should indicate $\boxed{8.8.8}$.
Should you make a mistake in turning the Power Switch on while simultaneously pressing buttons ④ and ⑤, the Station will start up normally and the Heating Element will begin warming up. If this should happen, turn the Station off and wait until it has again cooled to room temperature.
3. After confirming that the Digital Display indicates $\boxed{8.8.8}$, begin calibrating the station.
4. Lay the Station on its side. Using the supplied hex wrench, unscrew the screw (M4 × 5mm) labeled "CAL" on the bottom of the Station.
5. Press the "0" button. Using a straight-edge (—) screwdriver, adjust the screw labeled "CAL" on the bottom of the Station until the display indicates the room temperature (as noted from a room thermometer).

ex. : If the room temperature is 22°C (70°F), adjust the Digital Display to 22°C (70°F).

Caution : The tip temperature may vary depending on the type of soldering iron used (S, M or L type iron). Refer to the calibration chart for the correct calibration temperatures for each of these soldering irons.

The following chart contains values that are very close to standard values. HAKKO recommends rechecking the tip temperature with a thermometer whenever the Station is calibrated.

How to use Calibration Chart : When you use 900M-T-LB,

$$\text{adjust the Digital Display indicate } \frac{22(70)}{\text{Room Temp}} - \frac{2(4)}{\pm} = \frac{20(66)}{\text{Digital Display}}$$

6. Replace and tighten the screw (M4 × 5mm).

Caution : Do not use a screw that is longer than the original M4 × 5mm screw as it may damage the PC board inside the Station.

2. Standard Thermometer

1. Turn the Power Switch on and set the temperature to 400°C /750°F. Press the $\text{\textcircled{S}}$ (Set) button.
2. When the Digital Display indicates a tip temperature of 400°C /750°F, measure the actual temperature at the tip with a standard thermometer.
3. Using a straight-edge (—) screwdriver, adjust the screw labeled "CAL" on the bottom of the Station until the actual Tip temp, shows the same temp as Display shows.

Calibration Chart

900S		900M		900L	
No.	Room Tem., \pm	No.	Room Tem., \pm	No.	Room Tem., \pm
900S-T-1.2D	± 0	900M-T-1.6D	± 0	900L-T-B	± 0
900S-T-1.6D	± 0	900M-T-2.4D	± 0	900L-T-2B	± 0
900S-T-2C	± 0	900M-T-3.2D	± 0	900L-T-3.2D	± 0
900S-T-1C	± 0	900M-T-B	± 0	900L-T-2C	- 5°C, - 9°F
900S-T-B	± 0	900M-T-LB	- 2°C, - 4°F	900L-T-3C	± 0
900S-T-I	± 0	900M-T-1C	± 0	900L-T-4C	± 0
		900M-T-2C	± 0	900L-T-I	- 5°C, - 9°F
		900M-T-3C	± 0	900L-T-K	+ 5°C, + 9°F
		900M-T-K	+ 7°C, +12°F		
		900M-T-I	- 2°C, - 4°F		
		900M-T-H	- 5°C, - 9°F		

 **HAKKO**
HAKKO CORPORATION

HEAD OFFICE

4-5, SHIOKUSA 2-CHOME, NANIWA-KU, OSAKA, 556 JAPAN
TEL: (06) 561-3225 FAX: (06) 561-8466
TLX: HAKKOOSA J65274

OVERSEAS AFFILIATES

U.S.A.: AMERICAN HAKKO PRODUCTS, INC.
CORPORATE OFFICE

25072 ANZA DR. SANTA CLARITA, CA 91355, U.S.A.
TEL: (805) 294-0090 FAX: (805) 294-0096

S'PORE: HAKKO PRODUCTS PTE., LTD.
1, GENTING LINK #02-04, PERFECT INDUSTRIAL
BUILDING, SINGAPORE 1334
TEL: 7482277 FAX: 7440033

HONG KONG: HAKKO DEVELOPMENT CO., LTD.
ROOM 1706, ARION COMMERCIAL CENTRE, 2-12,
QUEEN'S ROAD WEST, HONG KONG
TEL: 815-1928 FAX: 541-8217

PHILIPPINES: HAKKO PHILS TRADING CO., INC.
NO. 415 WINDSOR TOWER CONDOMINIUM,
163 LEGASPI ST., LEGASPI VILLAGE MAKATI,
METRO MANILA, PHILIPPINES

TEL: 2-810-76-49 FAX: 2-810-76-49

MALAYSIA: HAKKO PRODUCTS SDN BHD
MALAYSIA HEAD OFFICE: PETALING JAYA
LOT 21/2 THE HIGHWAY CENTRE JALAN 51/205 46050
PETALING JAYA WEST MALAYSIA
TEL: 03-7941333 FAX: 03-7911232

PENANG BRANCH: TEL: 04-848669 FAX: 04-848628

JOHORE BAHRU BRANCH: TEL: 07-367766 FAX: 07-374655

2. 2.

Mar. 1993

MA00580ZB000509