

# HAKKO 470

DESOLDERING TOOL

## Desoldering Tool

# Instruction Manual

Thank you for purchasing the Hakko 470 Desoldering Tool.

This Manual describes the use and maintenance of the Hakko 470. Please read it before using the unit. After reading the manual, keep it in a safe place for future reference.

### Table of Contents

- Packing List**.....1
- Precautions, Specifications, Replacement Parts**.....2
- Part Names** (Desoldering Gun).....3
- (Station).....4
- Operation** (Preparation—
- Assembly and Connection).....5
- (Desoldering).....7
- (Cleaning During Operation).....9
- (Problems During Desoldering)...10
- (Troubleshooting Guide).....11
- Maintenance** (Desoldering Gun).....12
- (Station).....15
- Replacing the Heating Element**.....17
- Parts List** (Station).....19
- (Desoldering Gun).....21
- Wiring**.....22



# Packing List

Please check to make sure that all the items listed below are included in the Hakko 470 package

Station.....	1	Ceramic Paper Filter (S).....	2
Desoldering Gun.....	1	Ceramic Paper Filter (L).....	4
Iron Holder Base.....	1	Spring Filter.....	3
Spring Iron Holder.....	1	Cleaning Pin (for $\phi 1.0$ mm [0.04 in] nozzle).....	1
Cleaning Sponge.....	1	Cleaning Pin/L (for Heating Element).....	1
Filter Pipe.....	1	Cleaning Pin Holder.....	1
		Cleaning Drill (for $\phi 1.0$ mm [0.04 in] nozzle).....	1
		Instruction Manual.....	1
		Silicone Grease.....	1

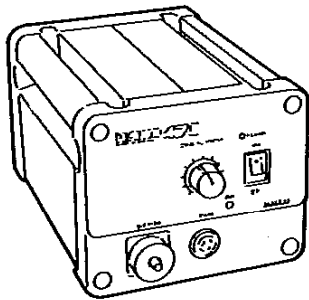

Station



Iron Holder Base

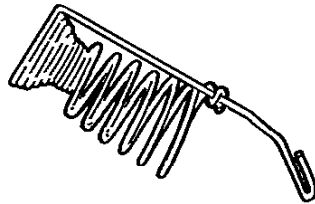

Spring Iron Holder

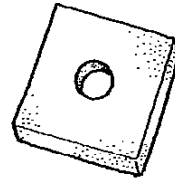

Cleaning Sponge

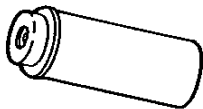

Filter Pipe

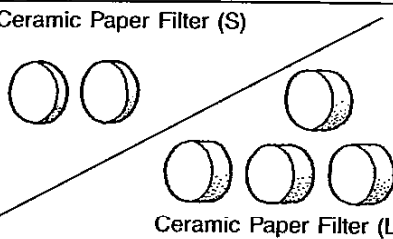

Ceramic Paper Filter (S)

Ceramic Paper Filter (L)

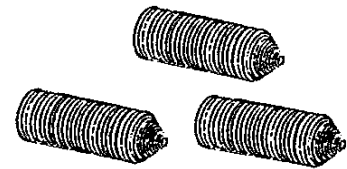

Spring Filter



Cleaning Pin for  $\phi 1.0$  mm (0.04 in) Nozzle

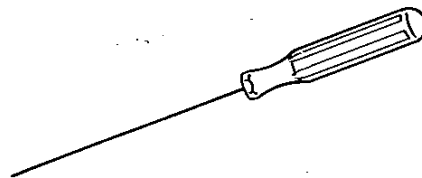

Cleaning Pin (L) for Heating Element

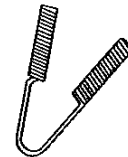

Cleaning Pin Holder

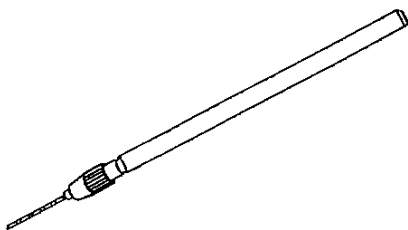

Cleaning Drill for  $\phi 1.0$  mm (0.04 in) Nozzle

1

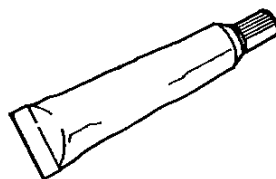

Silicone Grease

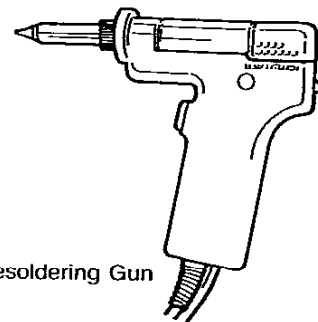

Desoldering Gun

# Precautions

## High Temperature

The Heating Element, Filter Pipe, other parts near these parts, and the Spring Iron Holder are all extremely hot during and immediately after operation. Be careful not to touch them at these times.

## Filter

Use Ceramic Paper Filter S/Filter Case (Station) and Ceramic Paper Filter L/Filter Pipe (Gun). Inversely setting may cause to break or the power to drop.

## Mishandling

Sharp impacts may cause parts to break or the power to drop. Handle both the Desoldering Gun and the Station with care.

## Maintenance

Please replace all expendable supplies and clean the specified parts.

# Specifications

Name	Hakko 470
Power Consumption	100W

### •Station

Part Name	Station
Output Voltage	24V AC
Vacuum Generator	Vacuum pump, double cylinder type
Vacuum Pressure (Max)	600 mm Hg (24 in Hg)
Suction Flow	12l/min.
Voltage Leakage	Under 1.2mV
Ground Resistance	Under 2Ω
Motor Output	12W
Outer Dimensions (W×H×D)	165×135×260 mm (6.5×5.31×10.24 in)
Weight	Approx. 5.0 kg (11.02 lb.)

### •Replacement Parts

Part No.	Part Name/Specification
A1002	Nozzle S φ0.8 mm (0.03 in)
A1003	Nozzle S φ1.0 mm (0.04 in)
A1004	Nozzle φ0.8 mm (0.03 in)
A1005	Nozzle φ1.0 mm (0.04 in)
A1006	Nozzle φ1.3 mm (0.05 in)
A1007	Nozzle φ1.6 mm (0.06 in)

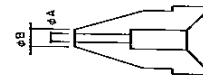
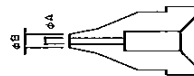

Part No.	φA	φB
A1002	0.8 (0.03 in)	1.8 (0.07 in)
A1003	1.0 (0.04 in)	2.0 (0.08 in)

Part No.	φA	φB
A1004	0.8 (0.03 in)	2.3 (0.09 in)
A1005	1.0 (0.04 in)	2.5 (0.1 in)
A1006	1.3 (0.05 in)	3.0 (0.12 in)
A1007	1.6 (0.06 in)	3.0 (0.12 in)

### •Desoldering Gun

Part Name	Hakko 802
Part No.	C1000
Power Consumption	24V AC, 50W
Temperature	380°C ~ 480°C (716°F ~ 896°F)
Insulation Resistance	Over 300 MΩ at 420°C (790°F)
Nozzle Inside Diameter	φ1.0 (0.04 in) (Nozzle S, Standard)
Outer Dimensions (W×H)	135×174 mm (5.31×6.85 in)
Weight (w/o cord, Hose)	Approx. 200g (0.44 lb)

Part No.	Part Name/Specification
B1215	Cleaning Pin (L) for Heating Element
B1086	Cleaning Pin for φ0.8 mm (0.03 in) Nozzle
B1087	Cleaning Pin for φ1.0 mm (0.04 in) Nozzle
B1088	Cleaning Pin for φ1.3 mm (0.05 in) Nozzle
B1089	Cleaning Pin for φ1.6 mm (0.06 in) Nozzle
B1302	Cleaning Drill for φ0.8 mm (0.03 in) Nozzle
B1303	Cleaning Drill for φ1.0 mm (0.04 in) Nozzle
B1304	Cleaning Drill for φ1.3 mm (0.05 in) Nozzle
B1305	Cleaning Drill for φ1.6 mm (0.06 in) Nozzle

Part No.	Part Name/Specification
B1017	Filter Pipe w/Front Holder & Filters
A1009	Ceramic Paper Filter (S) for Filter Case 10 pcs.
A1033	Ceramic Paper Filter (L) for Filter Pipe 10 pcs.
A1030	Spring Filter 10 pcs.
A1008	Heating Element 24V, 50W
A1028	Silicone Grease
A1042	Cleaning Sponge

### Condition of Measurement

#### •Insulation Resistance

The insulation resistance was measured between the Nozzle and the lead of the Heating Element using a 500 V DC insulation resistance meter.

Caution: The insulation resistance cannot be measured between the Nozzle and the power plug as the transformer between the secondary part (Heating Element) and the primary part acts as an insulator.

#### •Voltage Leakage

The voltage leakage was measured between the Nozzle and the grounding Plug at a temperature of 480°C (896°F) using an AC mV meter.

Caution: Be sure to ground the unit before measuring the voltage leakage.

\*Specifications are subject to change without notice.

# Part Names (Refer to pp. 19, 20, 21 for part nos.)

## ● Desoldering Gun

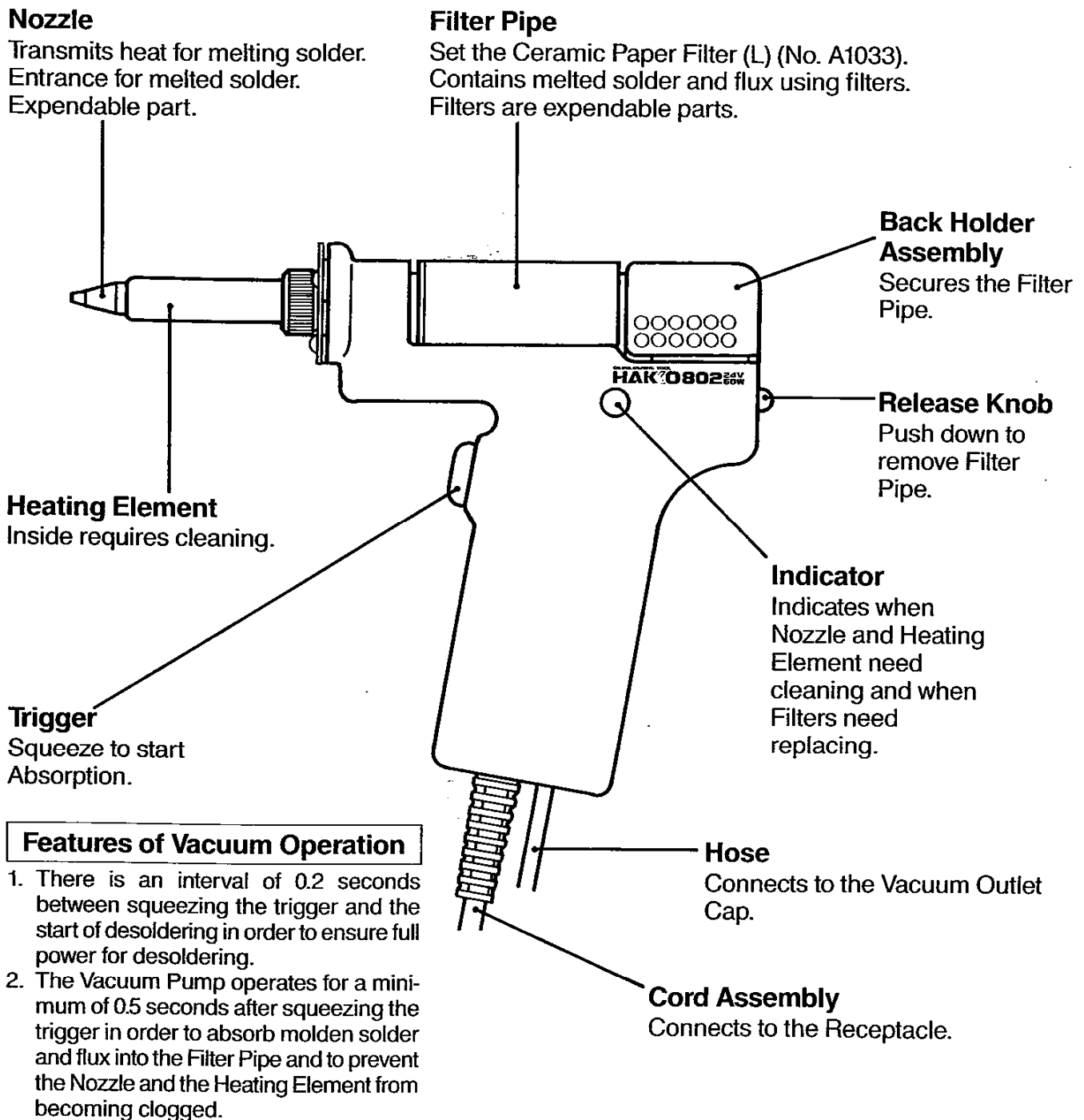

## ● Station

**Temperature Control Knob**  
Provides Nozzle temperature control. (refer to p.7)

**Temperature Control Knob Securing Screw**  
Prevents the Temperature Control Knob from being reset. (refer to p.7)

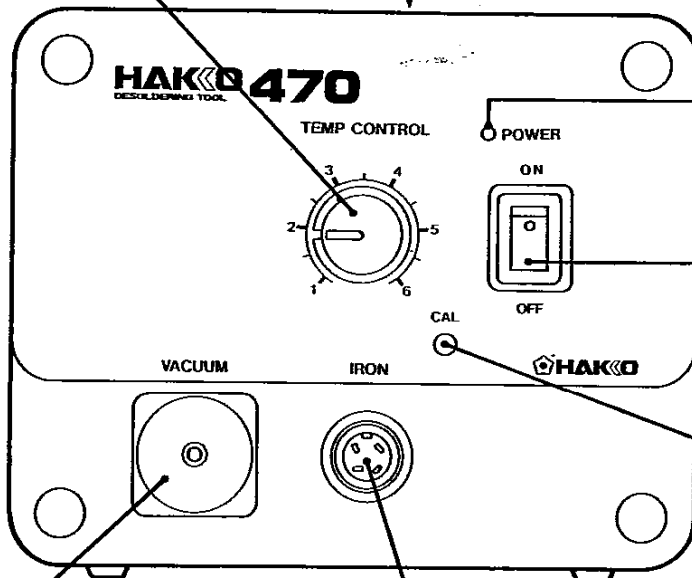

**Power Lamp**  
Lights up when the Power Switch is turned to ON.

**Power Switch**  
When turned to ON, the Heating Element starts to heat up.

**CAL (Calibration)**  
Used for calibrating the temperature after replacing the Heating Element.

**Vacuum Outlet Cap**  
Set the Ceramic Paper Filter (S) (No. A1009). Connects with the Hose. Filter inside Vacuum Outlet Cap is expendable.

**Receptacle**  
Connector for the Cord Assembly.

### Fuse Holder

- 100, 110, 120V Unit Contain 125-2A fuse.
- 220, 230, 240V Unit Contain 250-2A fuse.
- Australian 240V, U.K. 240V & Eur. 220, 230V Unit Contain 250-2A (S) fuse.
- SEMKO 230V Unit Contain 250V-1A (S) fuse.

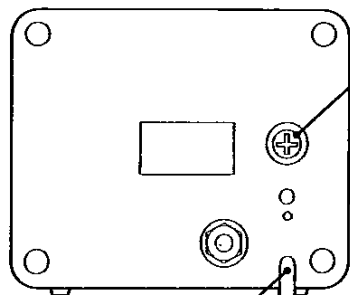

**Power Cord**

# Operation

## Preparation—Assembly and Connection

Assemble the Hakko 470 on a flat surface.

### ① Assemble the Iron Holder

- Set the Spring Iron Holder and Cleaning Pin Holder in the Iron Holder Base.
- Dampen the Cleaning Sponge with water and then squeeze it dry.

### ② Insert the Desoldering Gun and Cleaning Pins

- Fully insert the Desoldering Gun into the Spring Iron Holder.

**Caution:**

The Spring Iron Holder becomes extremely hot during operation of the Desoldering Gun. Do not touch the Spring Iron Holder during and immediately after using the Gun.

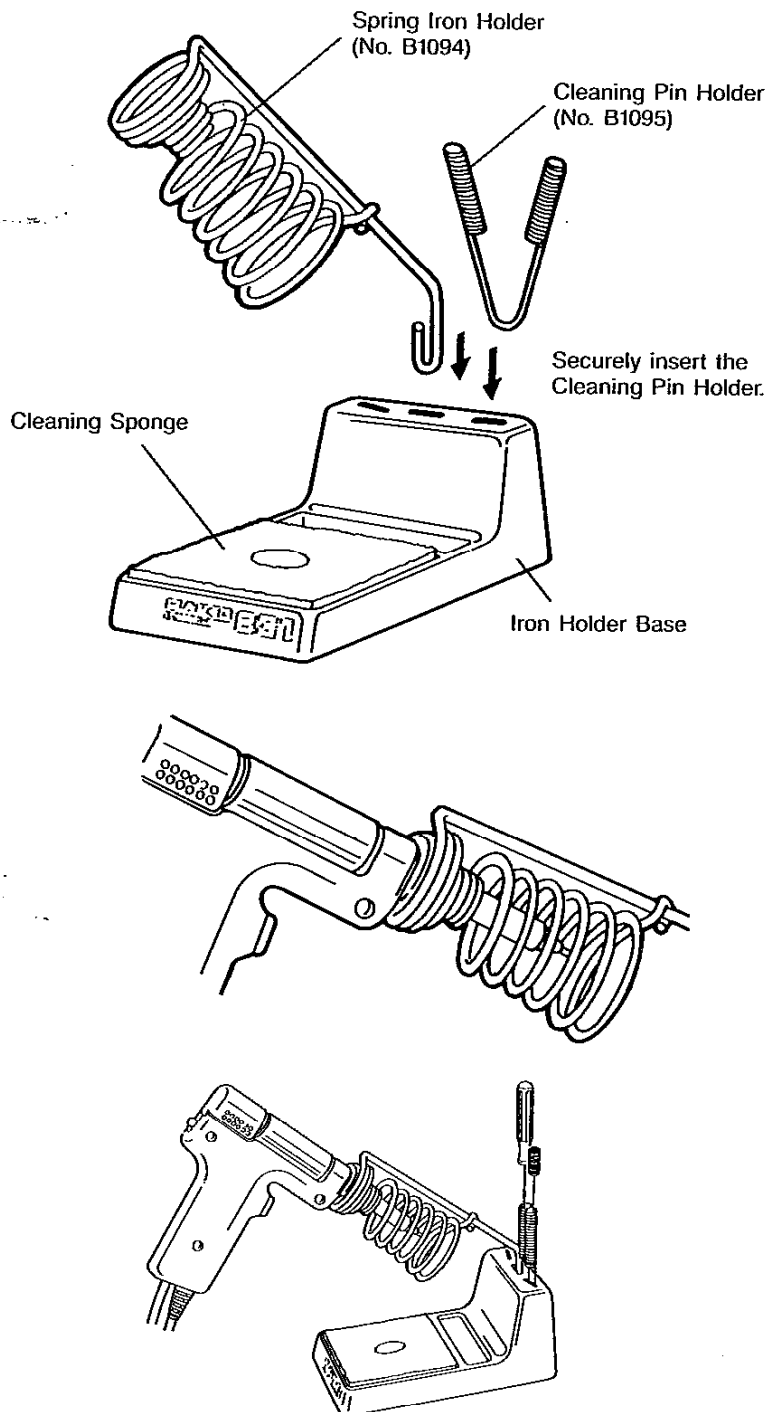

### ③ Connections

- Connect the Cord Assembly to the Receptacle (marked "IRON").
- Never connect or disconnect the Cord Assembly while the Power Switch is set to "ON".
- Connect the Hose to the Vacuum Outlet Cap (marked "VACUUM").

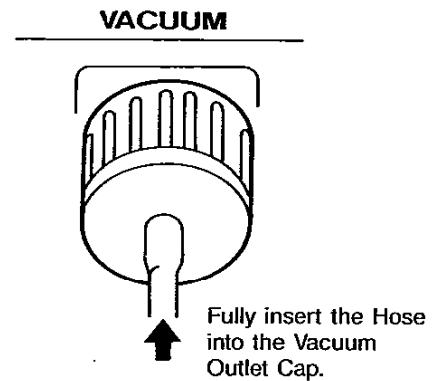
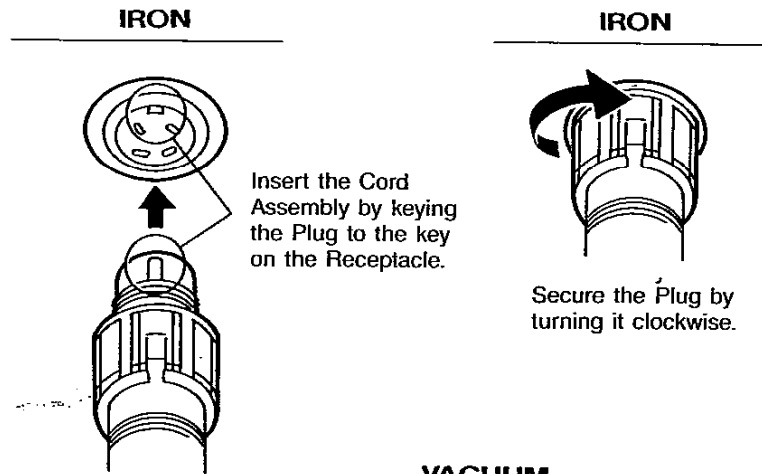

### ④ Power Switch

- Confirm that the Power Switch is set in the OFF position, then connect the power plug to the power source.

Note: The entire unit is constructed of conductive materials. Always ground the unit.

- Turn the Power Switch to ON. The Power Lamp should light up.
- The Nozzle begins to heat up as soon as the Power Switch is turned to ON.



ON

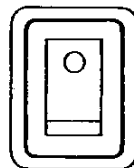

OFF

The Power Lamp lights up.



The Nozzle heats up.

**The Power Lamp doesn't light up.**

1. Is the Power Cord properly connected?
2. Is the fuse blown?

**The Nozzle doesn't heat up.**

1. Is the Cord Assembly properly connected?
2. Is the Heating Element broken?

- ⑤ After turning the Power Switch to ON, wait 3 minutes before beginning desoldering operations.

# Operation

## Desoldering

After turning the Power Switch to ON, wait 3 minutes before beginning desoldering operations.

### ① Set the temperature

Note: Always set the temperature to as low as possible for the work being done.

- To more precisely set the temperature, measure the temperature at the Nozzle using a soldering iron thermometer and adjust the Temperature Control Knob accordingly.

We recommend the Hakko 191 thermometer for measuring the Nozzle temperature.

- For volume desoldering, the Temperature Control Knob can be secured by tightening the Temperature Control Knob Securing Screw ("+" screw) at the top of the 470 unit.

### ② Clean the tip of the Nozzle

- Keep the solder-plated section of the Nozzle a shiny white by coating it with a small amount of solder.

If the tip of the Nozzle is coated with oxide, the Nozzle's heat conductivity will be lowered. Coating the tip with a small amount of fresh solder ensures maximum heat conductivity.

The Temperature can be adjusted between 380°C (716°F) and 480°C (896°F) ( $\pm 16^\circ\text{C}/\pm 30^\circ\text{F}$ ) with Temperature Control Knob.

This Unit has excellent thermal recovery to operate with lower temperature than conventional desoldering tool. We recommend to operate under position '2' (398°C,  $\pm 16^\circ\text{C}/750^\circ\text{F} \pm 30^\circ\text{F}$ )

Note: Never insert Cleaning Pin in the hole of Temp. Control Set Screw Clamp. As this may result in damage to the Unit.

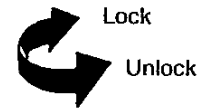

Secure the Temperature Control Knob Securing Screw with a plus (+) screwdriver.

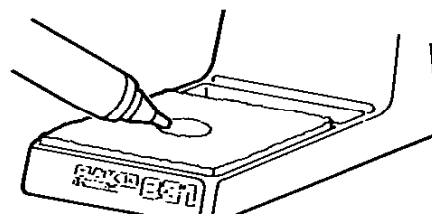
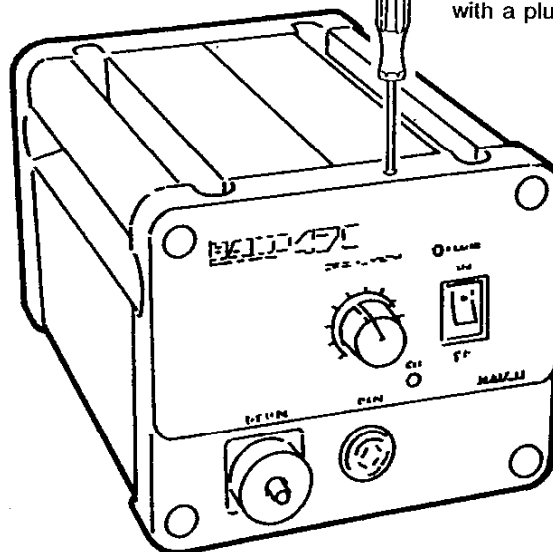

Wipe away any oxide or old solder from the Nozzle using the hole in the center of the sponge.



### ③ Melt the solder.

- Apply the Nozzle to the soldered part and melt the solder.

Note: Never allow the Nozzle to touch the board itself.

- Confirm that the solder is melted.

Note: To confirm that all the solder is melted, observe the inside of the hole and the backside of the PWB. If this is difficult to do, try slowly moving the lead with the Nozzle—if the lead moves, the solder is melted.

Note: Never move the lead by force. If it doesn't move easily, the solder isn't yet fully melted.

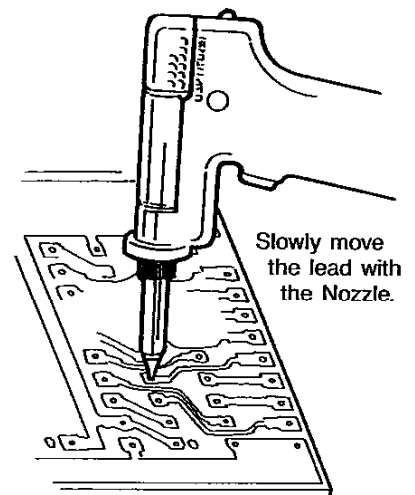
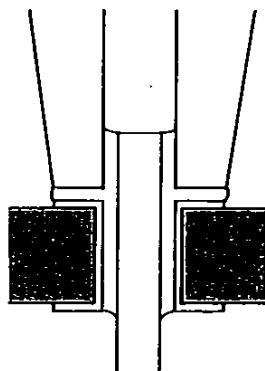
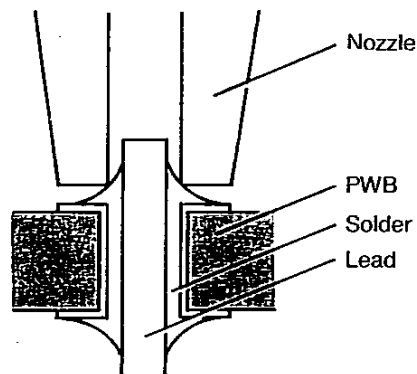

### ④ Absorb the solder.

- After confirming that the solder is completely melted, absorb the solder by squeezing the trigger on the Gun.

Note: Never leave any solder remaining inside the hole in the PWB.

- After fully absorbing all the solder, cool the soldering junction in order to prevent it from becoming resoldered.

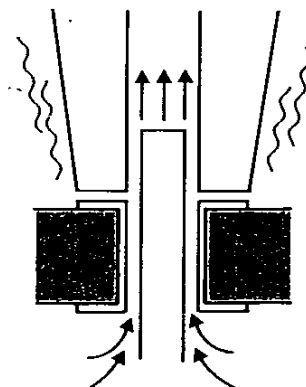

Absorb the solder by slowly moving the lead back and forth with the tip of the Nozzle.

### ⑤ Problems during Desoldering.

- If solder remains, resolder the component and repeat the desoldering process.

# Operation

Heated solder and flux can cause oxides to form and adhere to the Nozzle and the inside of the Heating Element. These oxides not only lower the heat conductivity, but can also clog the Nozzle and Heating Element, resulting in a drop in suction efficiency. Should there be a noticeable drop in suction efficiency during operation, replace the filter and clean the Nozzle and Heating Element with the provided Cleaning Pin.

## Cleaning during Operation

### ① Observing the Indicator



While looking at the indicator and with the hole of the Nozzle open, pull the trigger and look at the indicator. If it is red, clean the Nozzle and Heating Elements, empty the Filter Pipe, and replace the Filters. If the indicator is blue, cleaning is not necessary and operations can be resumed.

Note: The indicator will not operate accurately if the hole of the nozzle is closed or if the solder in the hole of the PWB is not melted.

Note: The indicator on Hakko 471 is read in a different way. For instructions on the reading of the 471 indicator, please refer to the Hakko 471 instruction manual.

### ② Replacing the Filter

During operation, the Filter Pipe is very hot. Wait until the Filter Pipe is cool before replacing the Filter. We recommend keeping a second Filter Pipe containing new Filters handy, and replacing the installed Filter Pipe with this backup Filter Pipe.

Normal	Abnormal	Solution
		If the indicator is more than half red, replace the filter and clean the Nozzle and the inside of the Heating Element. (refer to p.12, Maintenance of the Desoldering Gun)
Blue or slight amount of red can be seen.	More than half of the indicator is red.	

Replace the entire Filter Pipe with the provide backup Filter Pipe.

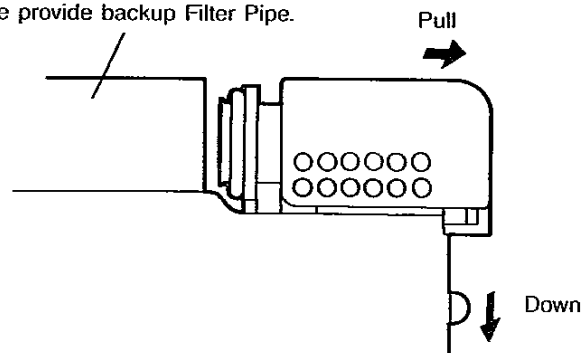

## Problems during Desoldering

- A. The solder in the junction is not sufficiently melted.
- B. Suction power is dropping.

### A. The solder in the junction is not sufficiently melted.

#### ● Temperature is not high enough.

The following parts require a greater heat capacity to desolder.

- Multi-layer PWBs, power supplies, ground planes in through-hole PWBs high-capacity transistors, triacs with heat radiation fins, tuner PWB ground wires, and large-scale transformer terminals.

Use a preheating oven or heating gun to heat the PWB to a temperature that won't damage the board or its components [between 70°C (160°F) and 80°C (180°F)], then desolder. Do not increase the temperature of the gun by recalibration as this may damage the PWB board and its components.

#### ● Nozzle is worn out.

- When the Nozzle begins to wear out, the heating efficiency begins to decline. Check the Nozzle. If the solder plating is damaged (p.12), or the Nozzle is eroded (p.12), replace the Nozzle.

### B. Suction Power is dropping.

- Replace the Filters, and clean the Nozzle and the inside of the Heating Element. (refer to p.12, Gun and Station Service)

#### ● Air is leaking from the vacuum system.

Air leakage cannot be determined from the indicator. Check the air-tightness of the following parts and replace any that are worn.

- |  |                          |
|--|--------------------------|
| a. Contact point of the Nozzle and Heating Element | c. O-ring in Back Holder |
| b. Front Holder and nearby parts.                  | d. Hose                  |
|  | e. Vacuum Outlet Cap     |

## Post-operation Maintenance

To ensure a long service life, always perform the following maintenance procedures immediately after using the Hakko 470 unit.

- Remove all solder from the inside of the Nozzle and Heating Element.
- Clean the tip of the Nozzle with the Cleaning Sponge, then coat the tip with a fresh layer of solder to protect the solder plating.

---

## Troubleshooting Guide

- **Power Lamp does not light up.**
  - **Is the Power Cord plugged in correctly?**  
Securely insert the Power Cord into the power supply.
  - **Is the Fuse blown?**  
Replace with a new fuse (2 amp.)
  
- **Pump does not operate.**
  - **Is the Cord Assembly properly connected?**  
Reconnect the Cord Assembly (p.6)
  - **Is the Nozzle or hole in the Heating Element clogged?**  
Clean it. (p.12)
  
- **Solder is not being absorbed.**
  - **Is the Spring Filter full of solder?**  
Replace it with a new one.
  - **Is the Ceramic Filter hardened?**  
Replace it with a new one.
  - **Is there a vacuum leak?**  
Check the connections and replace any worn parts.
  
- **The Nozzle does not heat up.**
  - **Is the Desoldering Gun Cord Assembly properly connected?**  
Reconnect it. (p.6)
  - **Is the Heating Element damaged?**  
Replace it.

Note: When repairs are needed, please send both the Desoldering Gun and the Station to your sales agent.

# Maintenance (Desoldering Gun)

Properly maintained, the Hakko 470 Desoldering Gun should provide years of good service.

Efficient desoldering depends upon the temperature, and the quality and quantity of the solder and flux. Perform the following service procedures as dictated by the conditions of the Gun's usage.

The Desoldering Gun will be extremely hot. During maintenance, please wear gloves and work carefully.

## Servicing the Desoldering Gun

### ① Inspect and clean the Nozzle

- Plug in the power cord, turn the Power Switch On and let the Nozzle heat up.
- Clean out the hole of the Nozzle with the Nozzle Cleaning Pin.

Note: The Cleaning Pin will not pass through the Nozzle until the solder inside the Nozzle is completely melted.

- Check the condition of the solder plating on the tip of the Nozzle.
- If it is slightly worn, recoat the tip with fresh solder to prevent oxidation.
- If it is severely worn, replace the Nozzle.
- Check the condition of the surface and inside hole of the Nozzle.
- If either is worn or eroded, or the inside diameter seems unusually wide, replace the Nozzle.

Note: The inside hole and the surface of the Nozzle is plated with a special alloy. Should this alloy become eroded by high-temperature solder, the Nozzle will not be able to maintain the proper temperature.

- If the Cleaning Pin and Cleaning Drill does not pass through the hole in the Nozzle, replace the Nozzle.

### Cleaning with the Nozzle Cleaning Pin

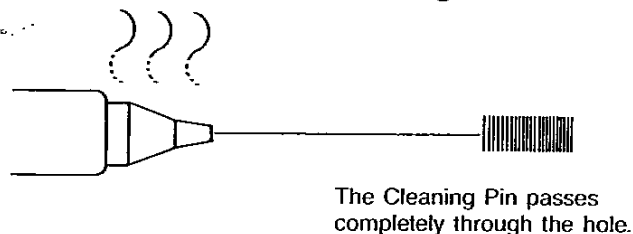

### Cleaning with the Cleaning Drill

#### •Before Cleaning

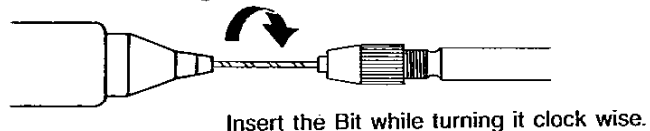

#### •After Cleaning

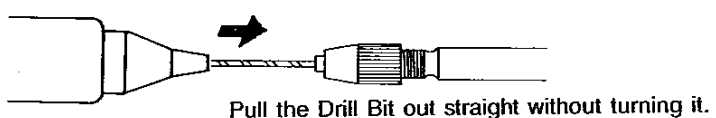

Caution:  
If the Cleaning Drill is forced into the Nozzle, the Drill Bit could break or be damaged.

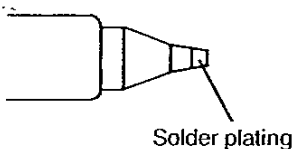

Caution:  
Please use the proper sized Cleaning Pin or Cleaning Drill for the Nozzle diameter.

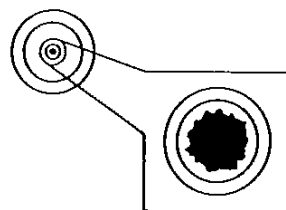

Diameter of hole is widened through erosion.

Note:  
Unfortunately, it is often difficult to observe this condition, therefore, if desoldering efficiency goes down and all other parts appear to be OK, the Nozzle is probably eroded and should be replaced.

## ② Disassemble the Heating Element

Caution: The Heating Element is very hot during operation.

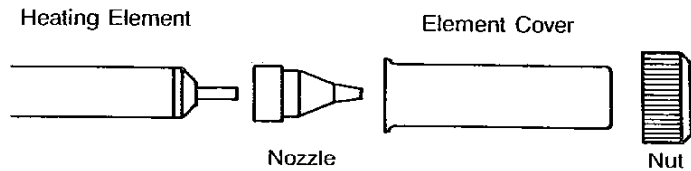

Remove the Nut.

## ③ Clean out the hole in the Heating Element

- Be sure the solder in the hole in the Heating Element is completely melted, then clean the hole with the provided Cleaning Pin.

Note: If the Cleaning Pin cannot pass through the hole, replace the Heating Element.

Scrape away all oxidation from the hole in the Heating Element until the Cleaning Pin passes cleanly through the hole.

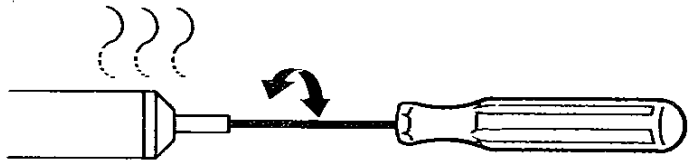

The Cleaning Pin passes cleanly and completely through the hole.

## ④ Replace the Filters

- Turn the Power Switch OFF.
- When the Filter Pipe is cool to the touch, push down the Release Knob at the back of the Gun and remove the Filter Pipe.

Front Holder

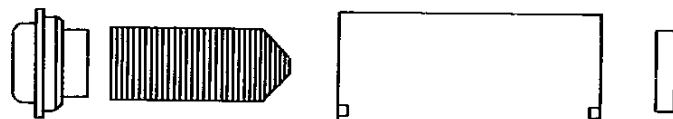

Spring Filter

Ceramic Paper Filter (L)  
(No. A1033)

- Examine the Front Holder.

Replace  
Stiff and cracked.

- Examine the Spring Filter.

Replace  
Solder is collected in two-thirds of the Spring Filter.

- Examine the Ceramic Paper Filter. (A1033)

Replace  
Ceramic Paper Filter is stiff with flux and solder.

### ⑤ Secure the filters

- Attach the Spring Filter to the Front Holder.
- Attach the Front Holder to the Filter Pipe.

Caution: Be sure the Front Holder is correctly aligned.

Caution: Use Ceramic Paper Filter (L) for Filter Pipe (Gun). Using of the Ceramic Paper Filter (S) in the Filter Pipe may cause to break or the power to drop.

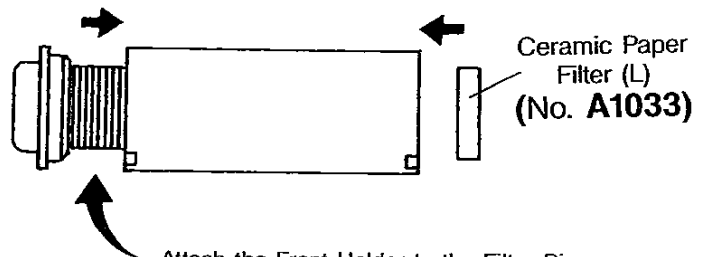
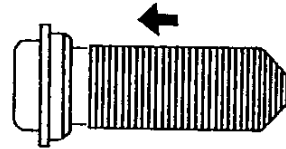

Firmly press the Back Holder Assembly into the Filter Pipe in order to properly seat the O-ring against the Pipe.

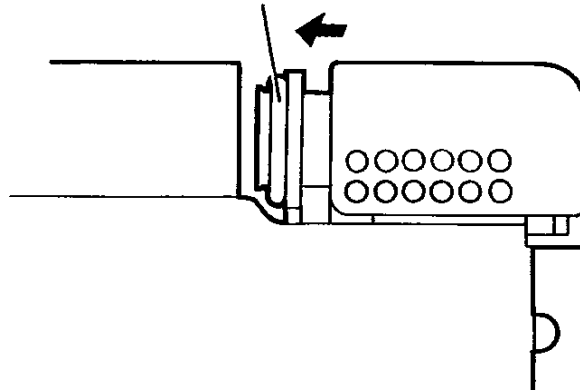

### ⑥ Assemble the Heating Element

- Attach the Nozzle and securely tighten the Nut.

Caution: If the nut is loose, air will leak and the temperature will drop.



# Maintenance (Station)

## Cleaning the inside of the Filter Case

### ① Replace the Ceramic Paper Filter (A1009)

Detach the Filter Retainer, being very careful not to let the Valve pop out. Remove the Ceramic Paper Filter and inspect it. If it is stiff with flux, replace it.

### ② Clean the Filter Retainer

Remove any flux adhering to the Filter Retainer.

### ③ Clean the Valve

Remove any flux adhering to the Valve.

Caution: Do not misplace the white washer that is attached to the Valve.

### ④ Reassemble the Filter Case

Caution: Set the Ceramic Paper Filter (S) for Filter Case (Station).

Using Ceramic paper Filter (L) in the Filter Case may cause to break or the power to drop.

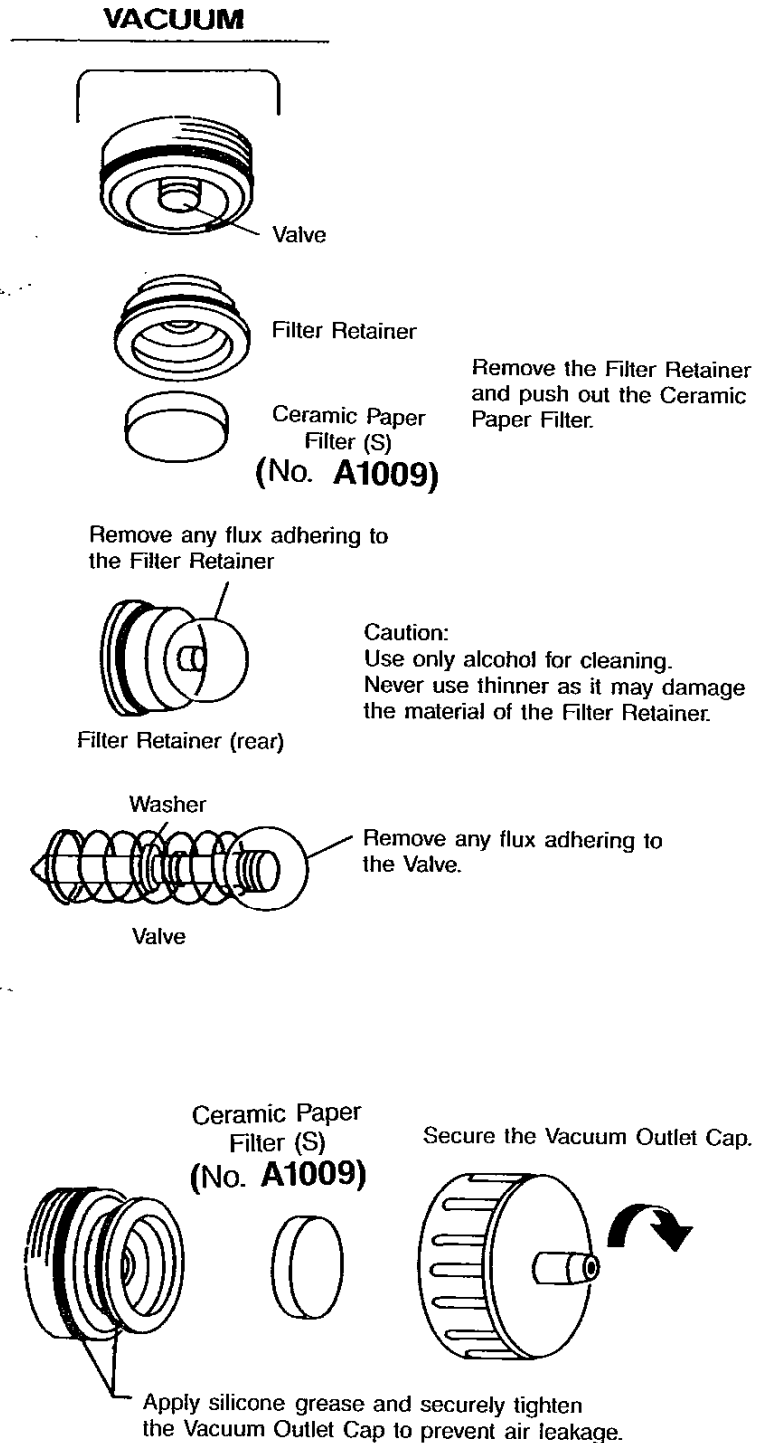



## Cleaning the Pump

Caution: Unplug the Power Cord before starting this procedure.

### ① Disassemble the Pump Heads

- Remove the Rear Panel
- Remove the Cover
- Remove the Pump Head from each side of the Pump.

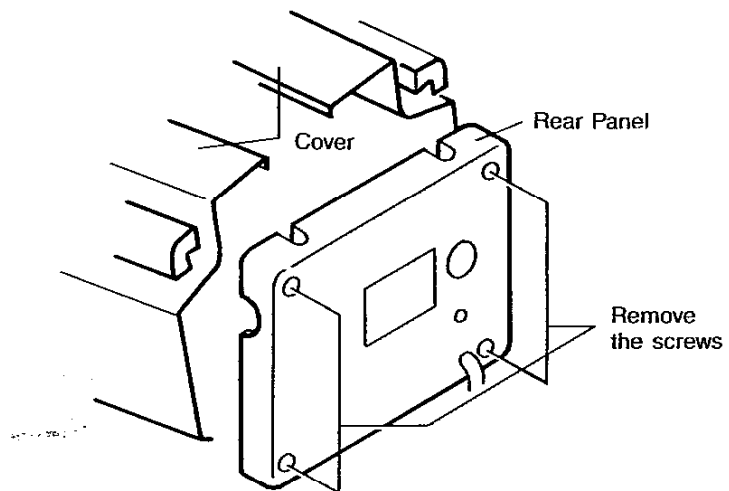

### ② Clean the Pump Head

- Remove the Valve Plate and Fixing Plate.
- Remove any flux adhering to the Plates.

#### Caution:

If the Fixing Plate is difficult to remove, apply hot air to it to warm it up. Never use excessive force to remove the Plate as it is easy to bend, and a bent Plate will allow air to leak out and reduce solder vacuuming efficiency.

#### Caution:

Clean the Plates only with alcohol or thinner.

#### Replace:

If the Valve Plate is bent or stiff, replace it.

- If the Exhaust Filter is dirty, replace it.

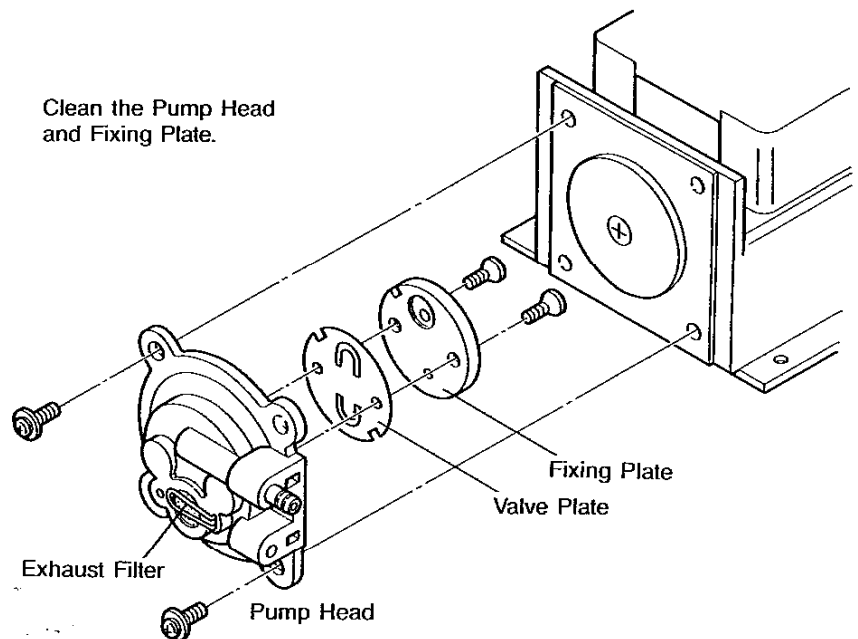

### ③ Assemble the Pump Heads

Reassemble the Valve Plate and Fixing Plate

#### Caution:

When assembling the Pump, be sure to check for air leaks.

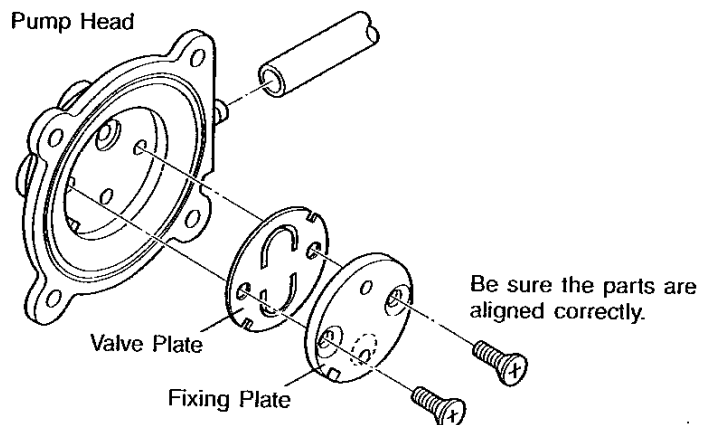

# Replacement Parts

## Replacing the Heating Element

The resistance value of a working Heating Element is  $2-4\Omega$  at  $23^{\circ}\text{C}$  ( $73^{\circ}\text{F}$ ). If the value you get is outside this range, replace the Heating Element.

### ① Disassemble the heating parts

Caution: Unplug the Power cord before starting this procedure.

### ② Separate the Housing.

### ③ Detach the Terminal and remove the Heating Element.

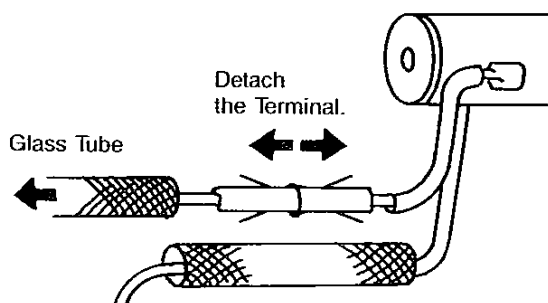
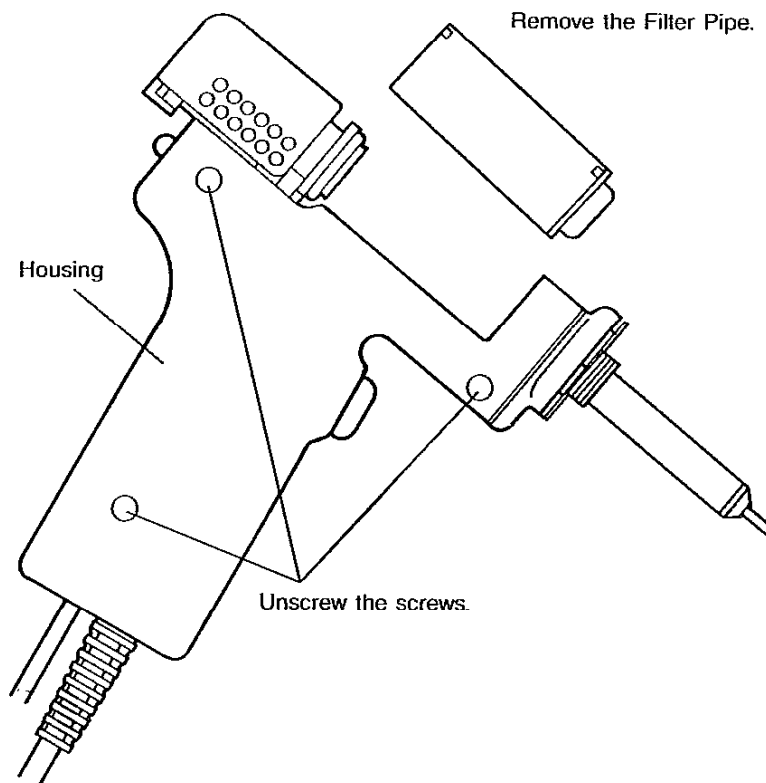
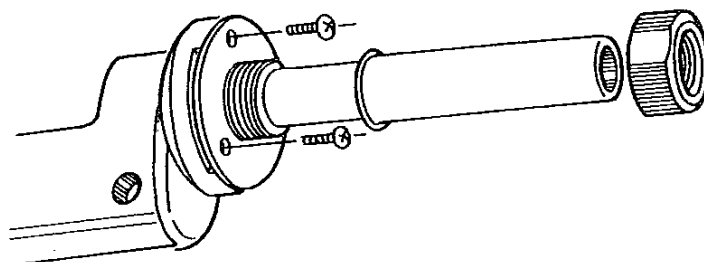

**④ Insert a new Heating Element and reassemble.**

(Heating Element 24V-50W)

Caution: Before reassembling enclosure, make sure connectors are completely covered by Glass Tube.

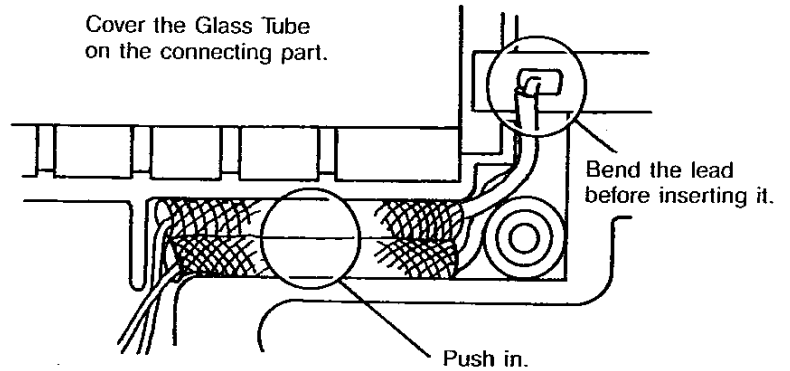

Position the leads in the groove and press them into place. Be careful that the leads do not get caught in the Housing.

**⑤ Recalibrate the temperature.**

The resistance of new Heating Elements varies, resulting in variations in operating temperatures. It is necessary to recalibrate the temperature every time the Heating Element is replaced.

1. Set the Temperature Control Knob to 1 and allow the Gun to warm up for 3 minutes.
2. Using a tip thermometer, adjust the temperature calibrator (marked "CAL") until the Nozzle temperature reads 380°C (716°F).

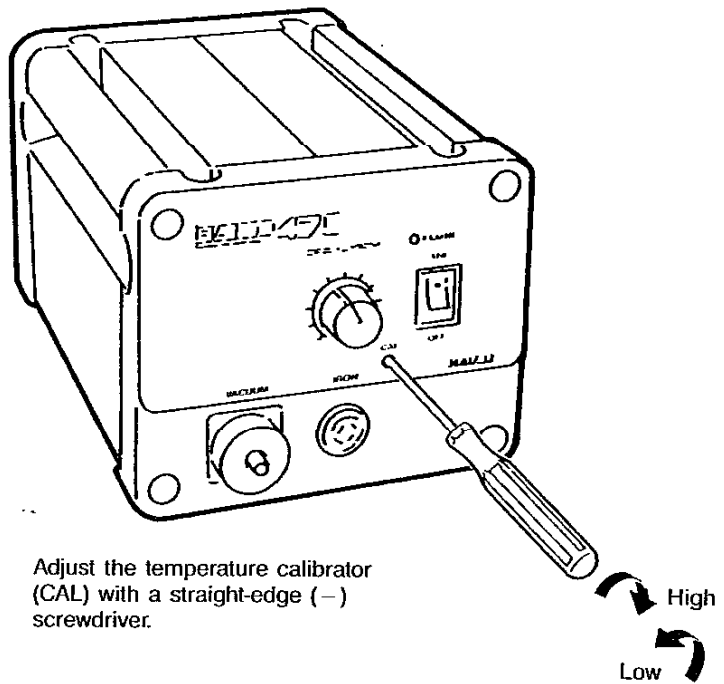

# Parts List (Station)

Item No.	Part No.	Part Name	Description
1	B1029	Vacuum Outlet Cap	
2	A1009	Ceramic Paper Filter (S)	10 pcs.
3	B1030	Filter Retainer	with Packing
4	B1035	Packing	
5	B1032	Valve	
6	B1031	Vacuum Outlet Retainer	with O-ring (S20)
7	B1034	O-ring (S20)	
8	B1033	Solenoid	with Valve
9	B1038	Cover for Securing Screw	set of 4
10	B1036	Receptacle	
11	B1028	Knob	
12	B1027	Front Panel	
13	B1093	Cover	one side
14	B1061	Handle	one side
15	B1044	Temp. Control Set Screw Clamp	
16	B1045	PWB	

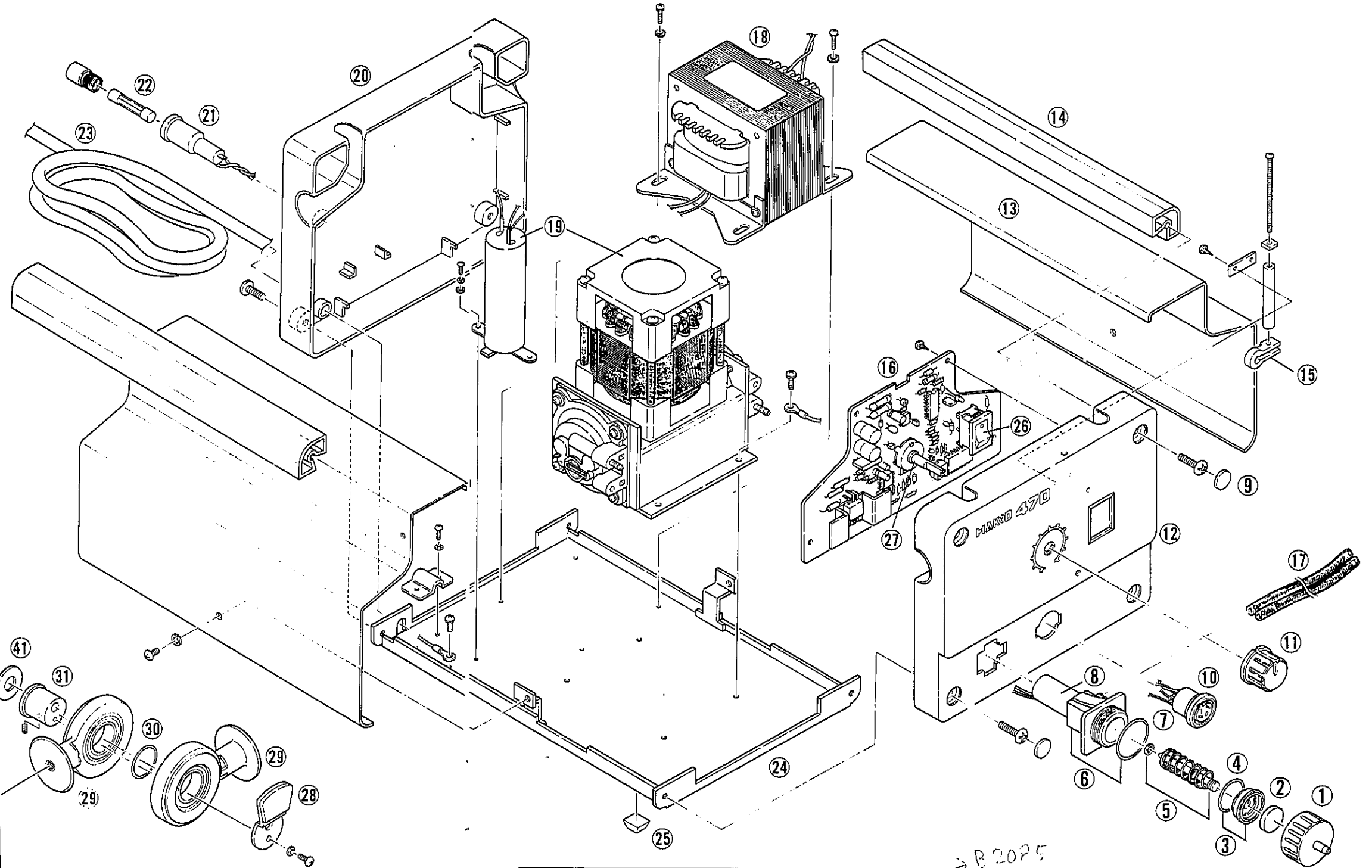

Item No.	Part No.	Part Name	Description
17	B1046	Hose	with Spring (set of 2)
18	B1060	Transformer	100-24V
	B1129	Transformer	110-24V
	B1131	Transformer	220-24, 230-24, 240-24V
19	B1047	Pump	with Motor Capacitor
20	B1040	Rear Panel	with Rating Seal
	B1041	Fuse Holder	w/o Fuse
21	B1134	Fuse Holder	w/o Fuse/for Australian 240V, U.K. 240V & Eur. 220, 230V
	B1042	Fuse	125V-2A/100, 110V
	B1132	Fuse	250V-2A/220, 230, 240V
	B1133	Fuse	250V-2A/S/Australian 240V, U.K. 240V & Eur. 220, 230V
22	B1133	Fuse	250V-2A/S/Australian 240V, U.K. 240V & Eur. 220, 230V
	B1139	Fuse	250V-1A/S/SEMKO

Item No.	Part No.	Part Name	Description
23	B1043	Power Cord	PNCTF 100V
	B1104	Power Cord	SVT 110V, 220V
	B1130	Power Cord	VCTF
	B1135	Power Cord	VSRF
	B1170	Power Cord	PVC
	B1716	Power Cord	PNCTF, Korean 220V
24	B1039	Chassis	
25	B1037	Rubber Stopper	set of 4
26	B1084	Switch	
27	B1078	Volume Type Temp. Control	
28	B1053	Balance Weight	
29	B1312	Crank	with bearing

B2025

Item No.	Part No.	Part Name	Description
30	B1057	Ring for Bearing	
31	B1049	Crank Shaft	
32	B1052	Pump Frame	
33	B1048	Motor	with Capacitor
34	B1055	Diaphragm Setting Plate	
35	A1013	Diaphragm	set of 2
36	B1056	Fixing Plate	
37	A1014	Valve Plate	set of 2
38	B1050	Pump Head	with Hose Connector
39	B1059	Exhaust Filter	set of 2
40	B1313	Filter Retaining Pin	
41	B1300	Plain Washer	6.5 mm x 15 mm x 2t

# Parts List (Desoldering Gun)

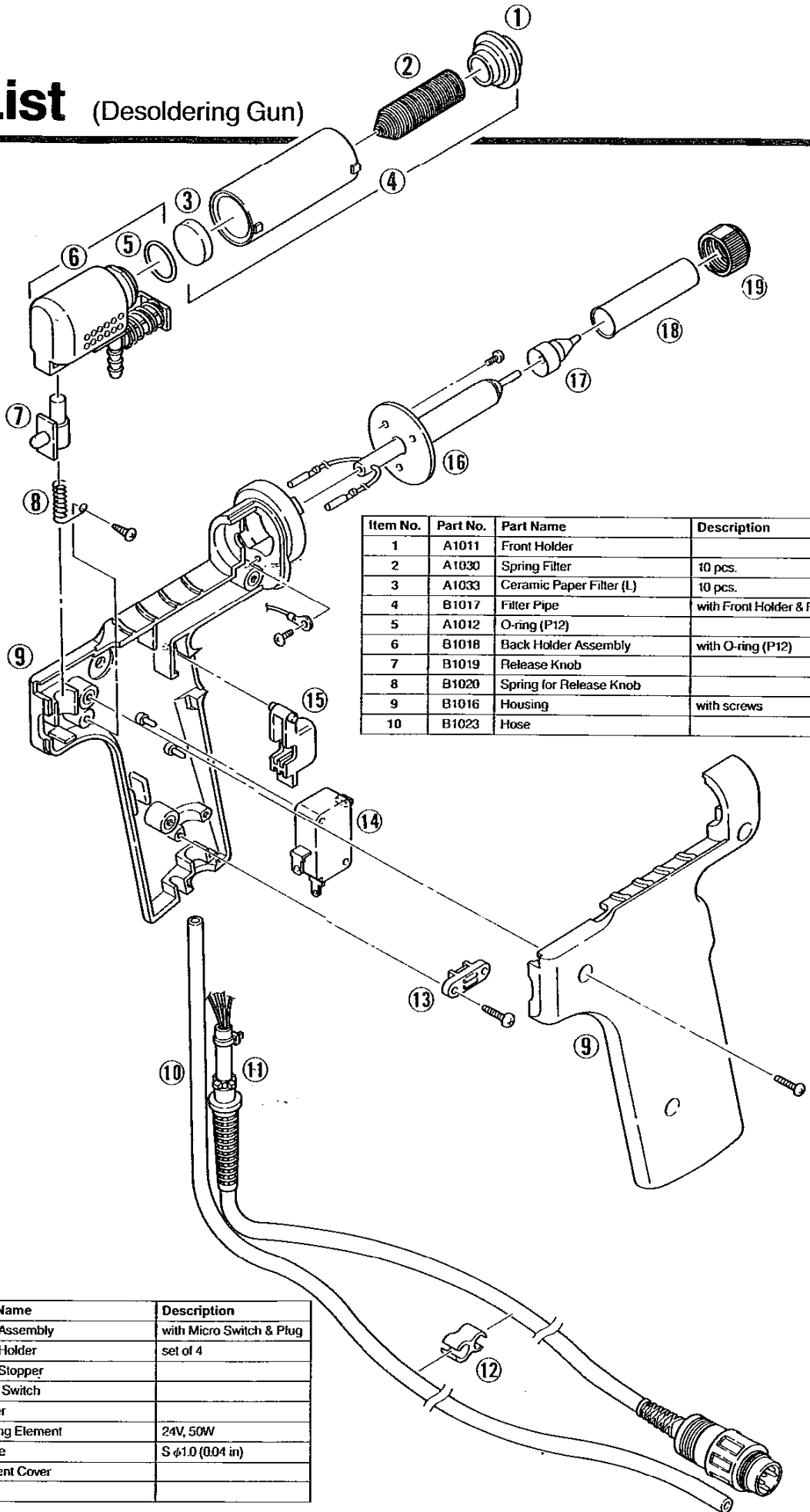

Item No.	Part No.	Part Name	Description
1	A1011	Front Holder	
2	A1030	Spring Filter	10 pcs.
3	A1033	Ceramic Paper Filter (L)	10 pcs.
4	B1017	Filter Pipe	with Front Holder & Filters
5	A1012	O-ring (P12)	
6	B1018	Back Holder Assembly	with O-ring (P12)
7	B1019	Release Knob	
8	B1020	Spring for Release Knob	
9	B1016	Housing	with screws
10	B1023	Hose	

Item No.	Part No.	Part Name	Description
11	B1025	Cord Assembly	with Micro Switch & Plug
12	B1024	Cord Holder	set of 4
13	B1022	Cord Stopper	
14	B1026	Micro Switch	
15	B1021	Trigger	
16	A1008	Heating Element	24V, 50W
17	A1003	Nozzle	S $\phi$ 1.0 (0.04 in)
18	B1014	Element Cover	
19	B1015	Nut	

# Wiring

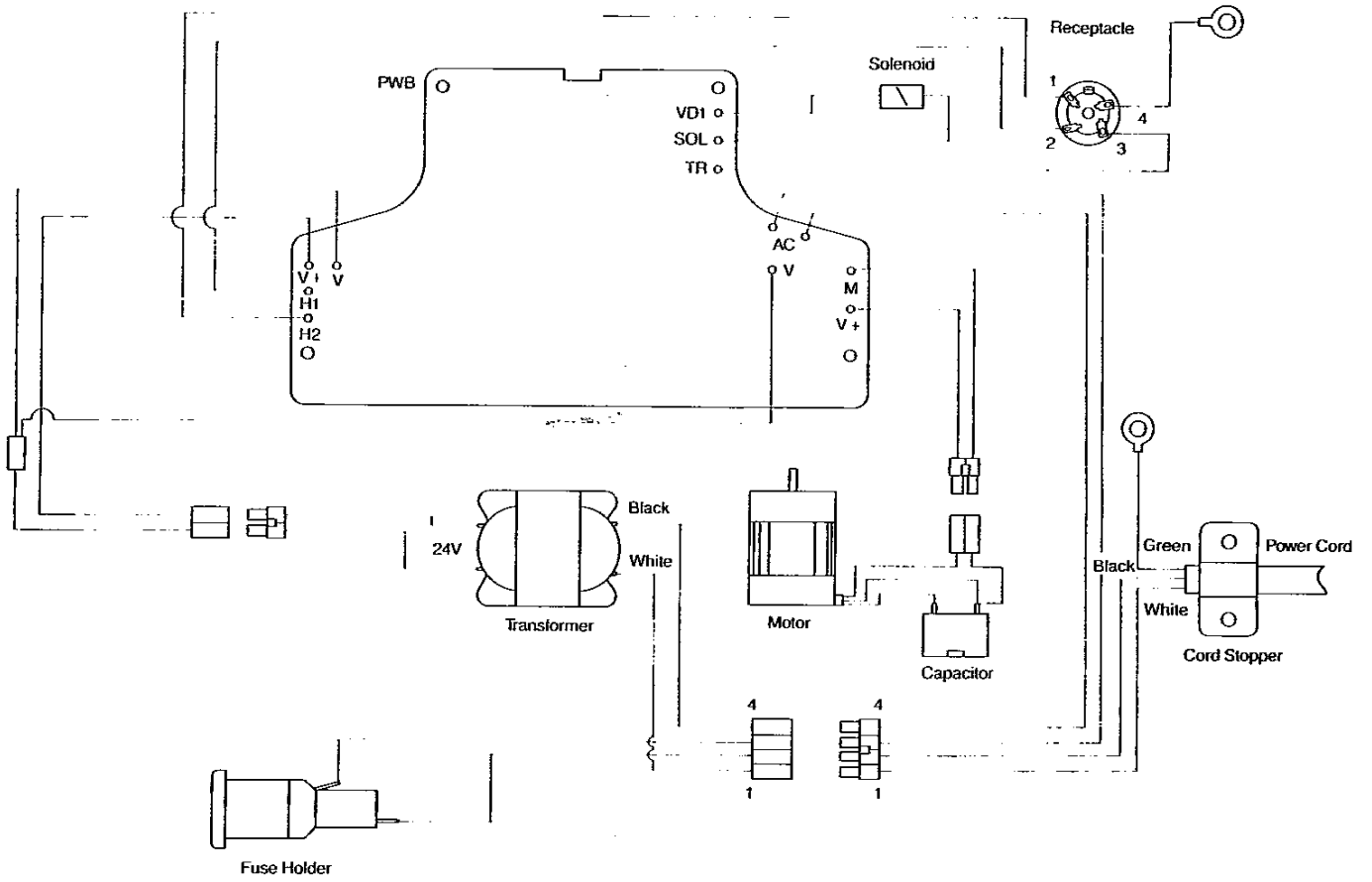

**THIS PRODUCT CONFORMS  
TO ELECTROMAGNETIC  
COMPATIBILITY  
DIRECTIVE 89/336/EEC**



**HAKKO**  
**HAKKO CORPORATION**

**HEAD OFFICE**

4-5, SHIOKUSA 2-CHOME, NANIWA-KU, OSAKA, 556 JAPAN  
TEL: (06) 561-3225 FAX: (06) 561-8466  
TLX: HAKKOOSA J65274

**OVERSEAS AFFILIATES**

**U.S.A.: AMERICAN HAKKO PRODUCTS, INC.**  
**CORPORATE OFFICE**

25072 ANZA DR. SANTA CLARITA, CA 91355, U.S.A.  
TEL: (805) 294-0090 FAX: (805) 294-0096

**S'PORE: HAKKO PRODUCTS PTE., LTD.**  
1, GENTING LINK #02-04, PERFECT INDUSTRIAL  
BUILDING, SINGAPORE 349518  
TEL: 7482277 FAX: 7440033

**HONG KONG: HAKKO DEVELOPMENT CO., LTD.**

ROOM 804 EASTERN HARBOUR CENTRE,  
28 HOI CHAK STREET, QUARRY BAY, HONG KONG.

TEL: 2811-5588 FAX: 2590-0217

**PHILIPPINES: HAKKO PHILS TRADING CO., INC.**

NO. 415 WINDSOR TOWER CONDOMINIUM,  
163 LEGASPI ST., LEGASPI VILLAGE MAKATI,  
METRO MANILA, PHILIPPINES

TEL: 2-810-76-49 FAX: 2-810-76-49

**MALAYSIA: HAKKO PRODUCTS SDN BHD**

**MALAYSIA HEAD OFFICE: PETALING JAYA**  
LOT 35/1 THE HIGHWAY CENTRE JALAN 51/205 46050  
PETALING JAYA WEST MALAYSIA

TEL: 03-7941333 FAX: 03-7911232

**PENANG BRANCH:** TEL: 04-846669 FAX: 04-848628

**JOHORE BAHRU BRANCH:** TEL: 07-2367766 FAX: 07-2374655