

**HAKKO 703B  
REWORK SYSTEM**

***TROUBLESHOOTING GUIDE***

THIS TROUBLESHOOTING GUIDE IS DIVIDED INTO FOUR PARTS:

1. FLOW DIAGRAMS DEPICTING THE PROCESS OF ANALYZING THE PROBLEM OR PROBLEMS.
2. TABLES DEPICTING NORMAL VALUES FOR VARIOUS COMPONENTS.
3. ILLUSTRATIONS SHOWING WHERE AND HOW TO PERFORM CERTAIN OPERATIONS.
4. DETAILED INSTRUCTIONS FOR CERTAIN OPERATIONS.

**- WARNING -**

ALWAYS DISCONNECT THE POWER PLUG BEFORE SERVICING THE HAKKO 703B.  
FAILURE SO TO DO MAY RESULT IN SEVERE ELECTRIC SHOCK.

# 1. System problems.

**PROBLEM: The unit does not operate.**

The power switch is turned ON; each station switch is turned ON.  
The Hakko 703B does not operate and none of the temperature displays light.

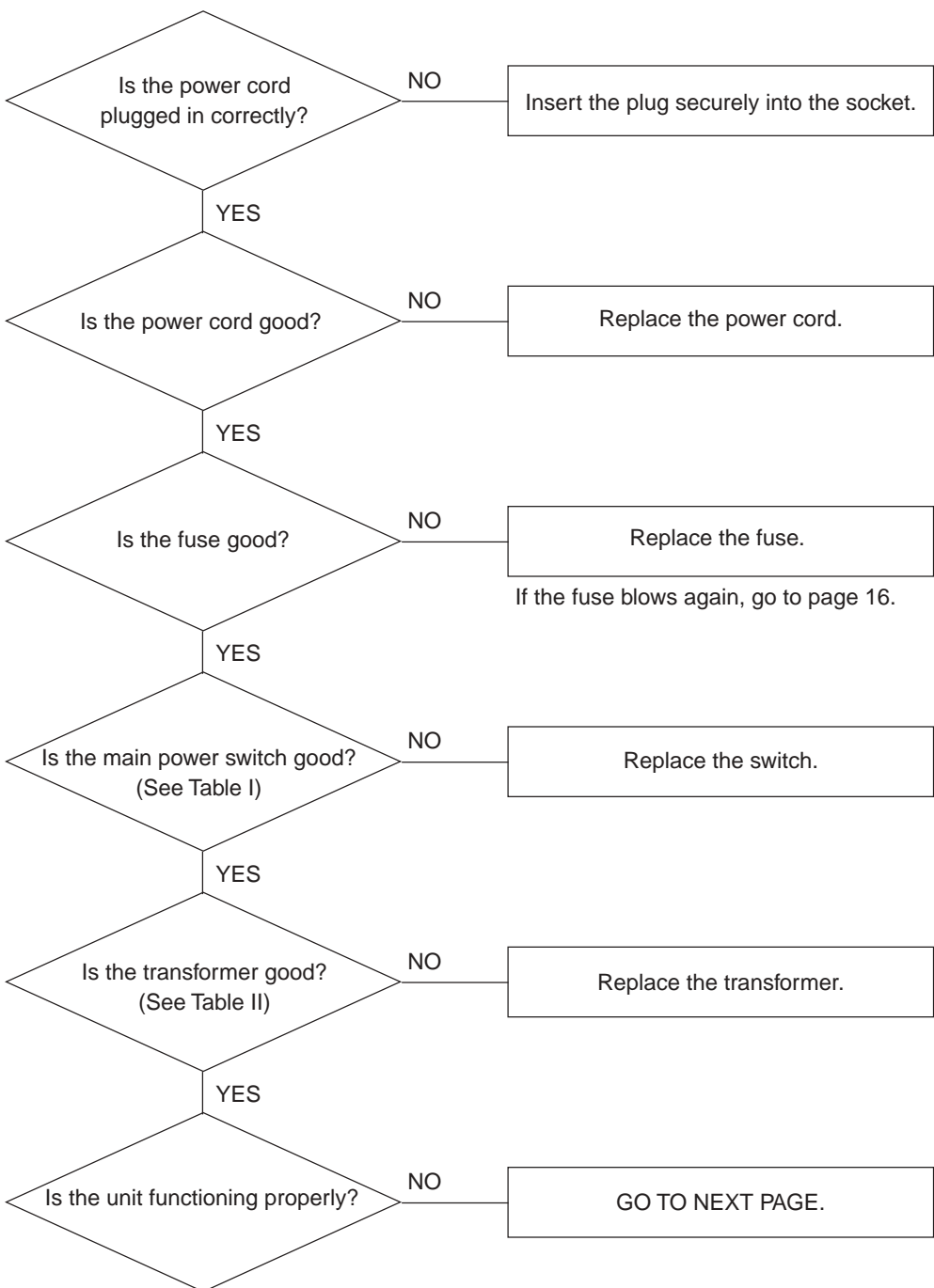

## 2. Error messages at turn-on.

**PROBLEM: The unit turns on, but error messages are displayed.**

The power switch is turned ON; each station switch is turned ON.  
 One or more digital displays show a system, heater, or sensor error.

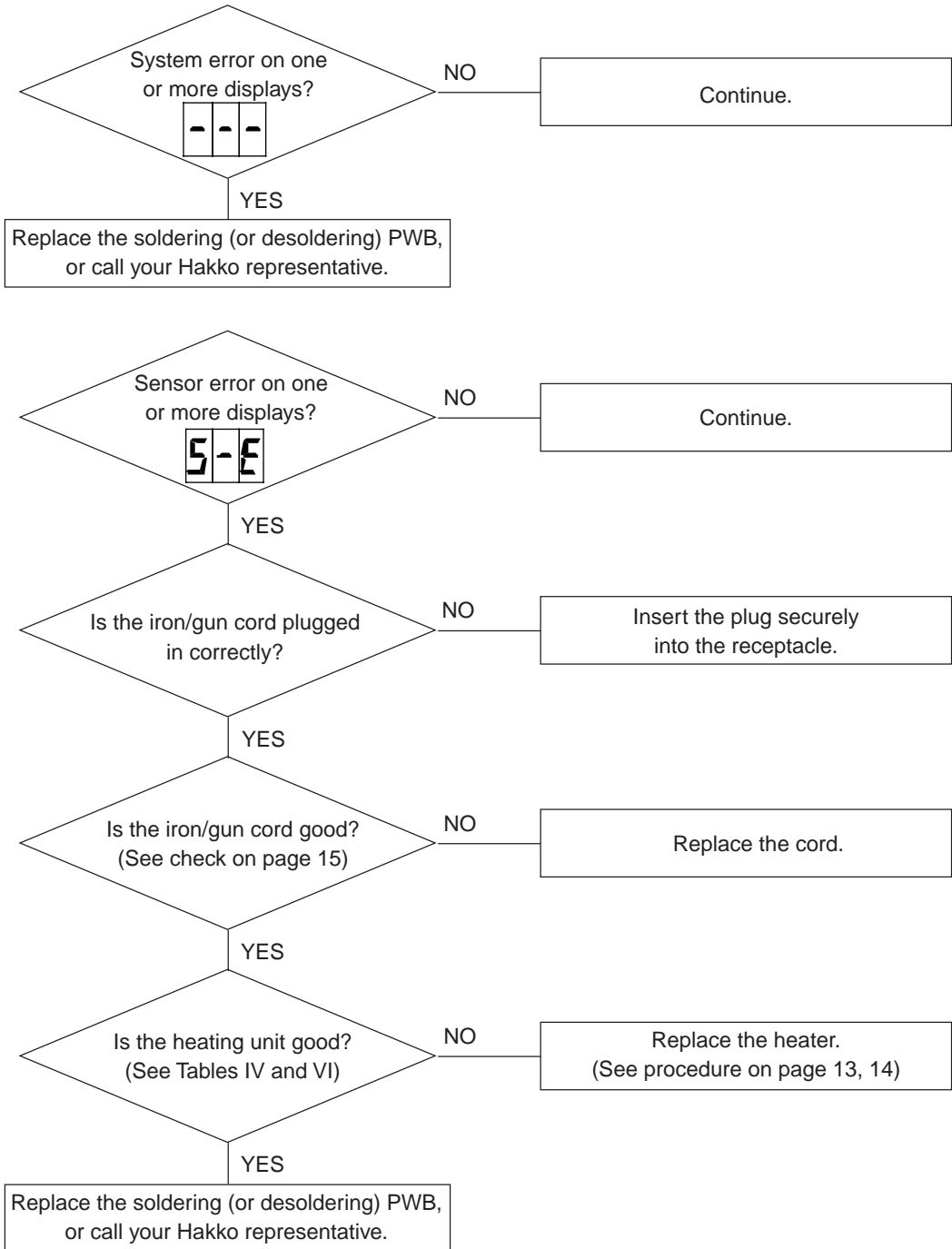

## 2. Error messages at turn-on, continued.

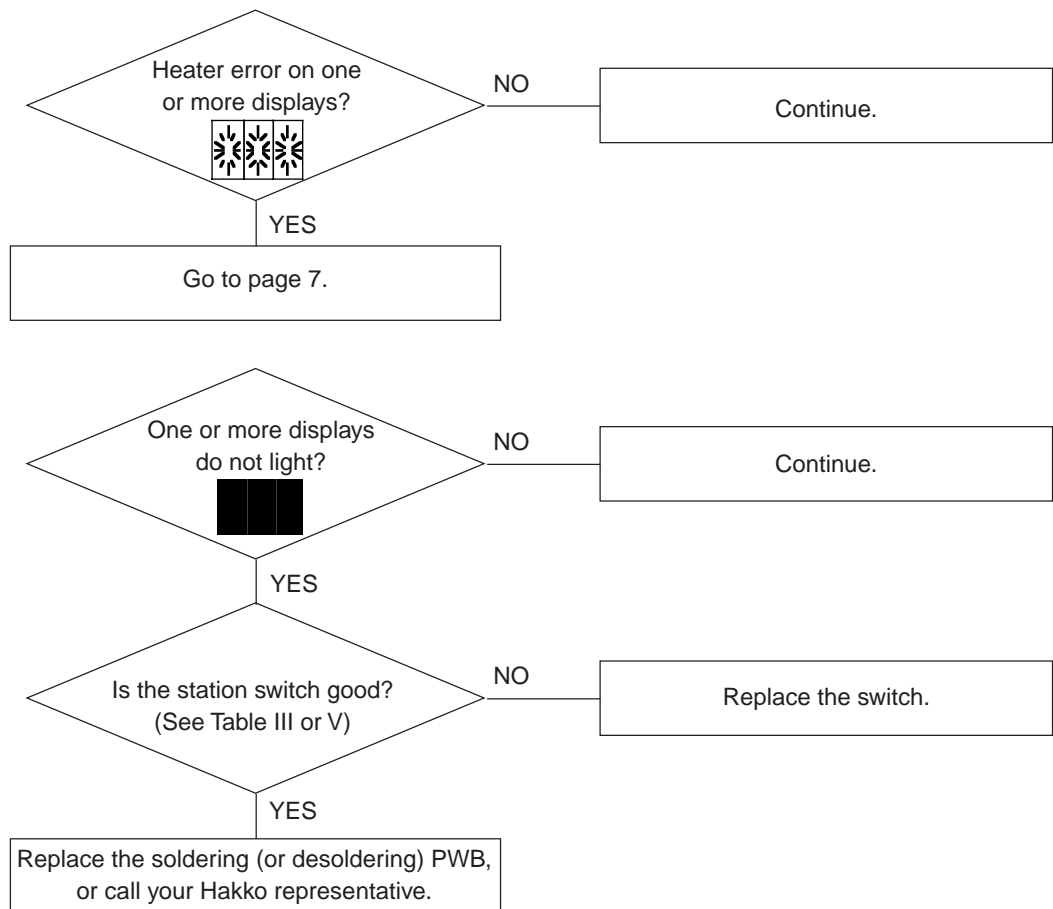

### 3. Basic station problems.

**PROBLEM: The tip or nozzle does not heat, or heats intermittently.**

The power switch is turned ON; the selected station switch is turned ON.  
No system, heater, or sensor error is displayed.

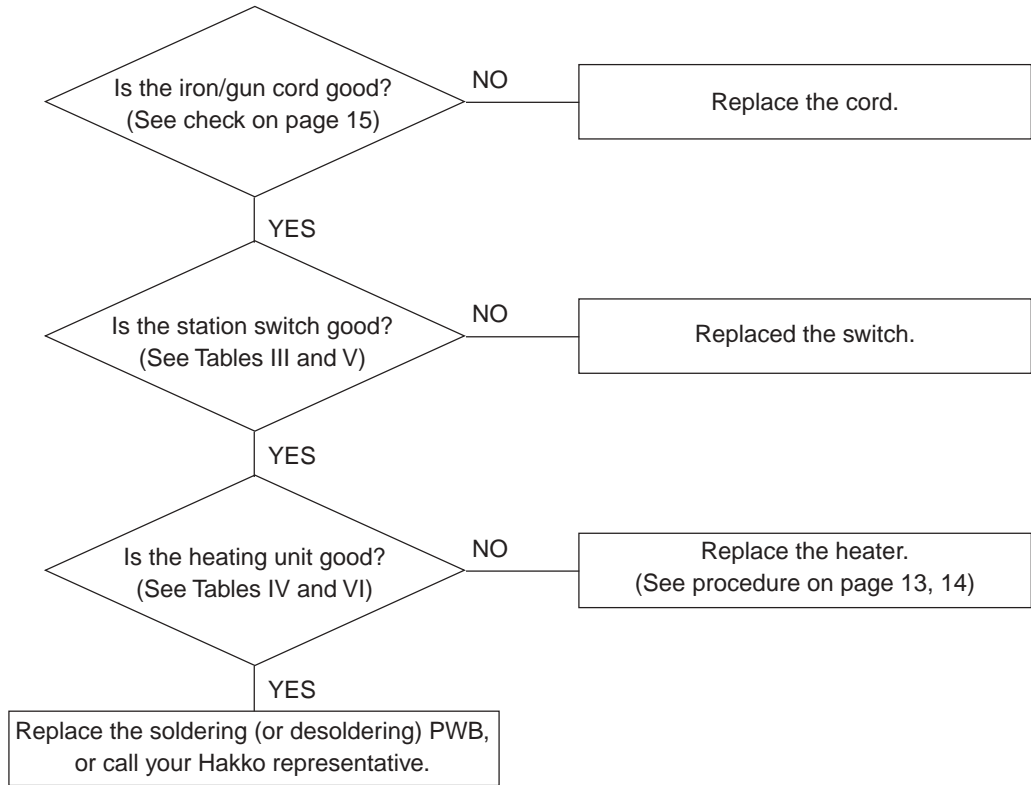

# 4. Soldering station problems.

**PROBLEM: The tip does not 'wet'.**

The power switch is turned ON; the selected soldering station switch is turned ON.  
No system, heater, or sensor error is displayed.

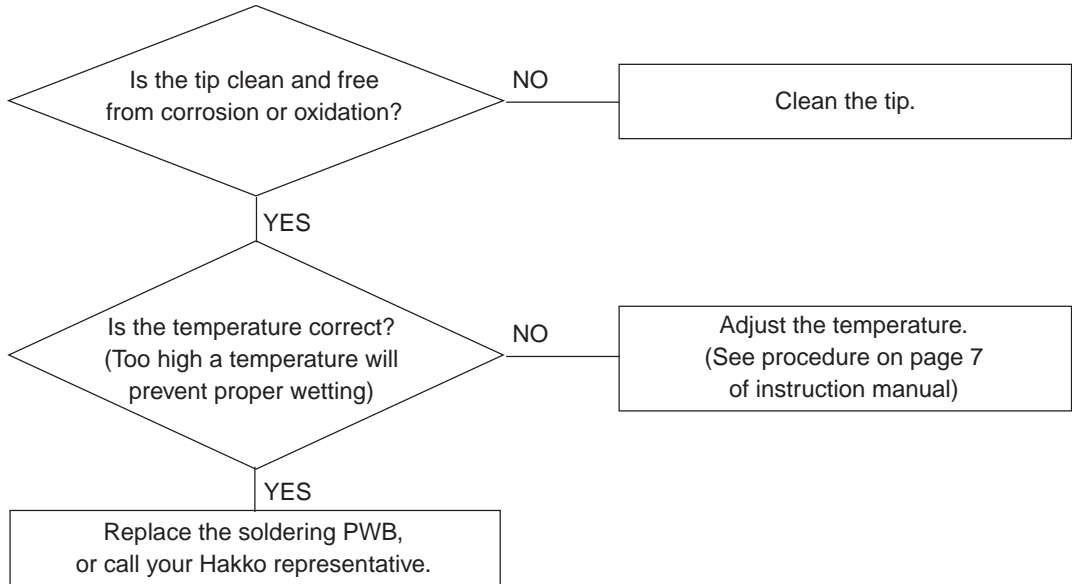

**PROBLEM: Soldering temperature is too low.**

The power switch is turned ON; the selected soldering station switch is turned ON.  
No system, heater, or sensor error is displayed.  
Temperature has been set.

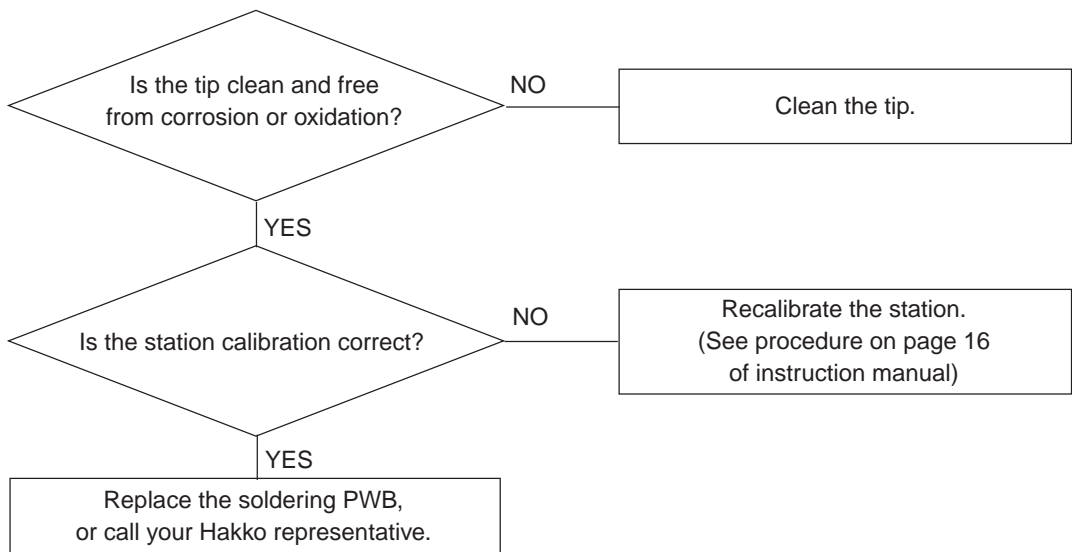

## 4. Soldering station problems, continued.

**PROBLEM: Intermittent heater errors (flashing display).**

The power switch is turned ON; the selected soldering station switch is turned ON.  
No system, heater, or sensor error is displayed.  
Temperature has been set.

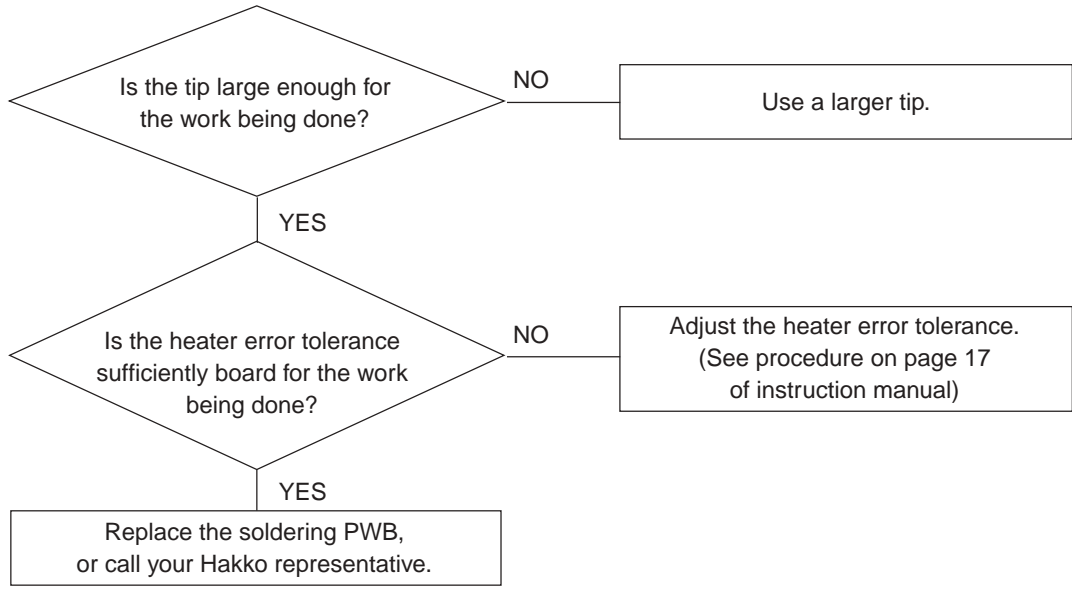



# 5. Desoldering problems.

**PROBLEM: The station does not extract solder.**

The power switch is turned ON; the station switch is turned ON.  
No error codes are displayed.  
The pump is working.

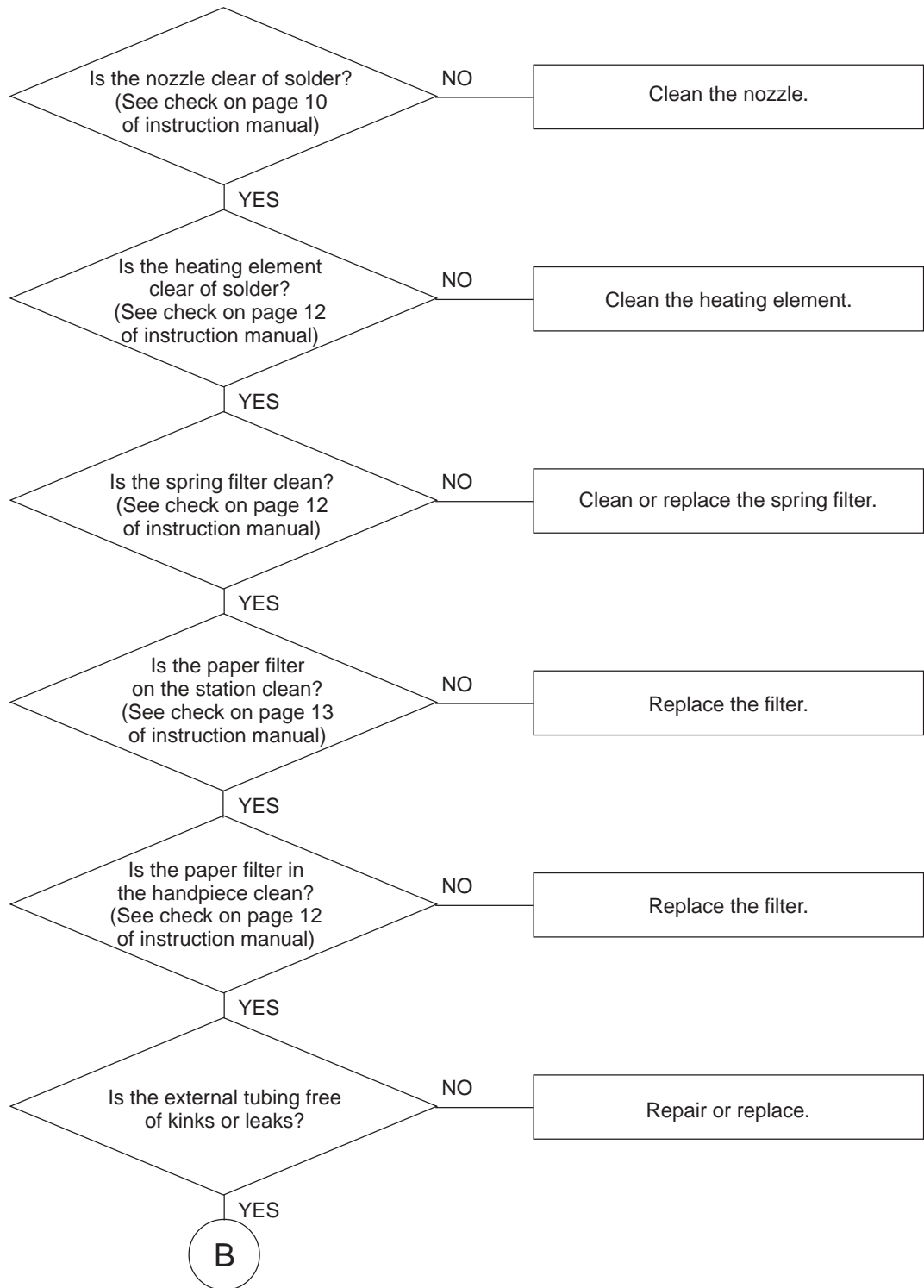

## 5. Desoldering problems, continued.

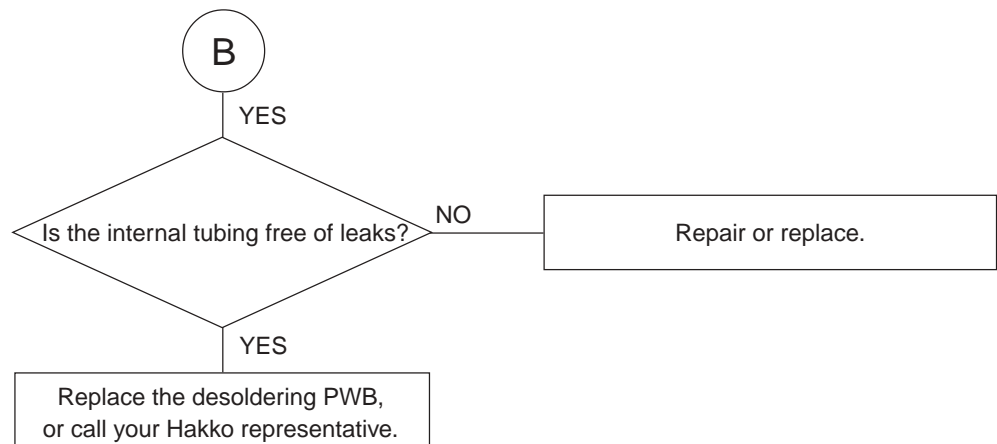

### PROBLEM: The pump does not work.

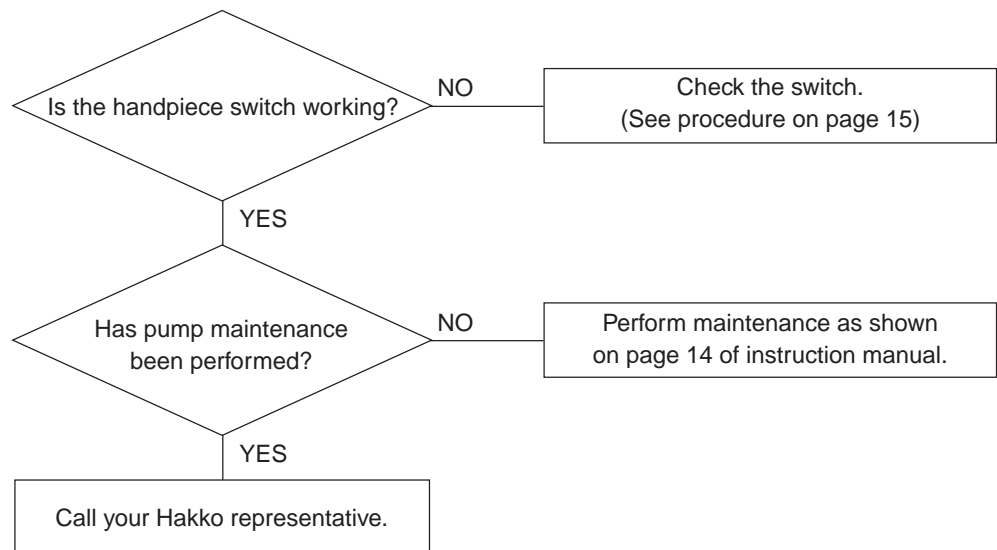

**NOTE:** SEE WIRING DIAGRAM ON PAGE 24 OF THE INSTRUCTION MANUAL WHEN MEASURING TABLE I & II.

**TABLE I.**  
MAIN POWER SWITCH CONTINUITY CHECK.

MEASURE BETWEEN	SWITCH ON	SWITCH OFF
PIN 1 OF CONNECTOR C1 AND PIN 3 OF CONNECTOR A1 (BLACK WIRES)	0 Ω	∞ (OPEN CIRCUIT)
CENTER PIN OF CONNECTOR C2 AND PIN 1 OF CONNECTOR A1 (WHITE WIRES)	0 Ω	∞ (OPEN CIRCUIT)

**TABLE II.**  
TRANSFORMER RESISTANCE CHECK.

MEASURE BETWEEN	RESISTANCE READING
PINS 1 AND 3 OF CONNECTOR A2.	2.8 Ω (PRIMARY WINDING)
TERMINAL 2 OF THE DESOLDERING IRON SWITCH AND THE CENTER PIN OF CONNECTOR B1.	0.1 Ω (0-10 V SECONDARY WINDING)
TERMINALS 1 AND 2 OF THE DESOLDERING IRON SWITCH.	0.2 Ω (0-24 V SECONDARY WINDING)

**TABLE III.**  
SOLDERING STATION SWITCH CONTINUITY CHECK.

MEASURE BETWEEN	RESISTANCE READING
INPUT AND OUTPUT SIDES OF SWITCH WITH SWITCH OFF.	∞ (OPEN CIRCUIT)
INPUT AND OUTPUT SIDES OF SWITCH WITH SWITCH ON.	0 Ω

**TABLE IV.**  
SOLDERING IRON HEATER RESISTANCE CHECK.

MEASURE BETWEEN	RESISTANCE READING
PINS 1 AND 2 OF THE SOLDERING IRON CORD (SENSOR)	43 TO 58 Ω
PINS 4 AND 5 OF THE SOLDERING IRON CORD (HEATER)	2.5 TO 3.5 Ω
PIN 3 OF THE SOLDERING IRON CORD AND THE TIP	UNDER 2 Ω

**TABLE V.**  
DESOLDERING STATION SWITCH CONTINUITY CHECK.

MEASURE BETWEEN	RESISTANCE READING
INPUT AND OUTPUT SIDES OF SWITCH WITH SWITCH OFF.	∞ (OPEN CIRCUIT)
INPUT AND OUTPUT SIDES OF SWITCH WITH SWITCH ON.	0 Ω

**TABLE VI.**  
DESOLDERING IRON/GUN HEATER RESISTANCE CHECK.

MEASURE BETWEEN	RESISTANCE READING
PINS 1 AND 3 OF THE DESOLDERING IRON CORD (HEATER)	APPROX. 9.2 Ω
PINS 2 AND 4 OF THE DESOLDERING IRON CORD (SENSOR)	APPROX. 54 Ω

NOMINAL VALUES GIVEN ARE FOR 23°C (73°F). RESISTANCE WILL INCREASE WITH TEMPERATURE.

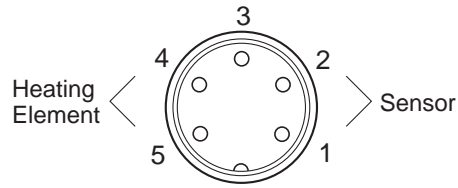

**FIGURE 1.**  
SOLDERING STATION CONNECTOR

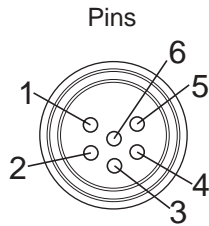

**FIGURE 2.**  
DESOLDERING STATION CONNECTOR

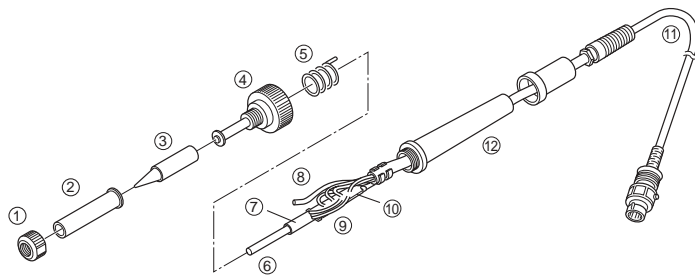

**FIGURE 3.**  
907, 908 SOLDERING IRON

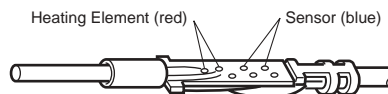

**FIGURE 4.**  
HEATER CONNECTIONS, SOLDERING IRON

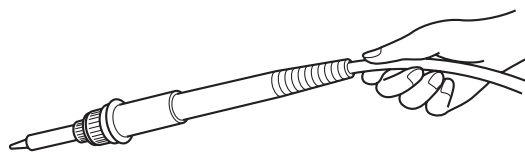

**FIGURE 5.**  
TESTING THE SOLDERING IRON CORD

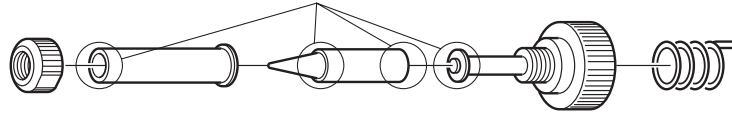

**FIGURE 6.**  
907, 908 SOLDERING IRON (THE POINTS TO RUB)

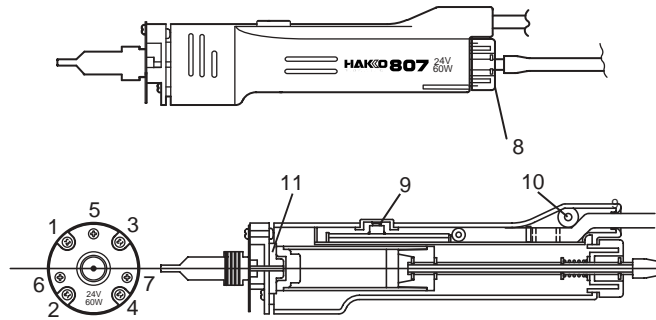

**FIGURE 7.**  
HAKKO 807 DESOLDERING IRON

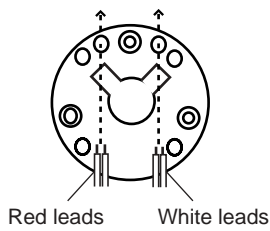

**FIGURE 8.**  
DESOLDERING IRON FLANGE

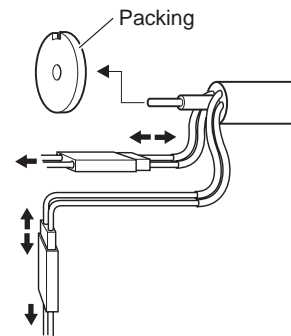

**FIGURE 10.**  
DESOLDERING GUN TERMINAL

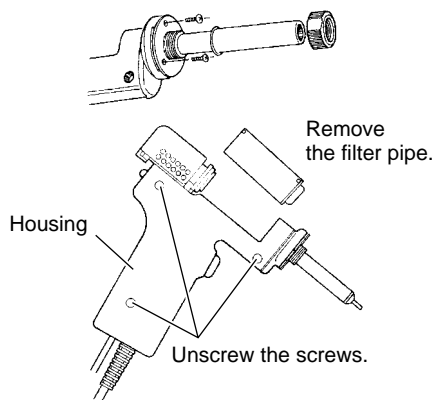

**FIGURE 9.**  
HAKKO 817 DESOLDERING GUN

## PROCEDURES.

### A. PRINTED WIRING BOARD TEST, REMOVAL AND REPLACEMENT, SOLDERING, DESOLDERING

1. VISUALLY INSPECT THE BOARD FOR EVIDENCE OF PHYSICAL DAMAGE (BURNS, CRACKS, LIFTED LEADS&C)
2. CHECK THE RESISTANCE BETWEEN PINS OF THE TRIAC. THEY SHOULD BE AS FOLLOWS:  
Between T1 and T2 – open circuit ( $\infty$ )  
Between T2 and ground – open circuit ( $\infty$ )  
Between T1 and ground – 150 to 400  $\Omega$
3. REPLACE THE BOARD IF THERE ARE SIGNS OF DAMAGE, OR IF THE TRIAC RESISTANCE IS NOT AS SHOWN.

### B. PRINTED WIRING BOARD TEST, REMOVAL AND REPLACEMENT, DISPLAY

1. VISUALLY INSPECT THE BOARD FOR EVIDENCE OF PHYSICAL DAMAGE (BURNS, CRACKS, LIFTED LEADS&C)
2. IF A DISPLAY OF DISPLAYS MALFUNCTION, REPLACE THE BOARD.

### C. REPLACING HEATERS

#### SOLDERING IRONS:

1. CHECK FOR A BROKEN HEATING ELEMENT OR CORD ASSEMBLY.

(1) Disconnect the connecting plug.

(2) Measure the resistance value between pins 1 and 2 (the sensor). See Fig. 1. It should be between 43  $\Omega$  and 58  $\Omega$ .

(3) Measure the resistance value between pins 4 and 5 (the heating element). See Fig. 1. It should be between 2.5  $\Omega$  and 3.5  $\Omega$ .

If either of the two measured values are outside their acceptable ranges, it will be necessary to replace the heating element, sensor and/or cord assembly.

(4) Measure the resistance value between pin 3 and the tip. It should be less than 2  $\Omega$ .

If it is not, there may be oxidation. Using fine sandpaper or steel wool, lightly rub the areas of the tip indicated in Fig. 6.

2. DISASSEMBLE THE SOLDERING IRON

Disassembling the 907/908 (See Fig. 3.)

(1) Turn the nut ① counterclockwise and remove the tip enclosure ② and the tip ③ .

(2) Turn the nipple ④ counterclockwise and remove it from the iron.

(3) Pull both the heating element ⑥ and the cord assembly ⑩ toward the tip of the iron and out of the handle ⑫ .

(4) Pull the grounding spring ⑤ out of the sleeve.

### 3. MEASURE THE RESISTANCE

Measure the resistance when the heating element is at room temperature.

- The resistance value between the blue leads (sensor) should be between 43  $\Omega$  and 58  $\Omega$ .
- The resistance value between the red leads (heating element) should be between 2.5  $\Omega$  and 3.5  $\Omega$ .

If either of the resistance values is outside the acceptable range, replace the heating element.

After replacing the heating element, measure the following resistance values.

- Between pin 4 and pin 1 or 2.
- Between pin 5 and pin 1 or 2.

If both values are not  $\infty$ , the heating element and the sensor are touching, which will damage the PWB.

Finally, remeasure the following resistance values to confirm that the leads are not twisted and that the grounding spring is properly connected.

- Between pins 1 and 2 (43  $\Omega$  – 58  $\Omega$ )
- Between pins 4 and 5 (2.5  $\Omega$  – 3.5  $\Omega$ )
- Between pin 3 and the tip (under 2  $\Omega$ )

Instructions for installing a new heating element for 907/908 is included with the replacement part.

### DESOLDERING IRON:

#### REPLACING THE HEATING ELEMENT

The resistance values of a working heating element are 9.2  $\Omega$  between pins 1 and 3 (heating element), and 54  $\Omega$  between pins 2 and 4 (sensor) at 23°C (73°F) — Fig. 2. If the measured values are outside this range, replace the heating element.

(No. A1174 24V-60W heating element for Hakko 807)

1. Unplug the power cord.
2. Disassemble the heating parts.
3. Turn the back holder knob counterclockwise and pull out the filter pipe.
4. Remove the housing fastener (8) — Fig. 7.
5. Remove the screws securing the housing (10) and the flange (3), (4) — Fig. 7.
6. Remove the front holder (11) — Fig. 7.
7. Remove the screws (5), (6), (7) securing the heating element to the flange, and the screws (1), (2).
8. Desolder the heating element and Sensor leads.
9. Secure a new heating element (24 V – 60 W) to the flange with screws (5), (6), (7). Install the heater in such a way that the lead wires are oriented as in Fig. 8.
10. Install the front holder.
11. Resolder the heating element and sensor leads.
12. Reassemble the unit.
13. Recalibrate the temperature.

### DESOLDERING GUN:

#### REPLACING THE HEATING ELEMENT.

#### CHECK THE RESISTANCE VALUE

The resistance values of a working heating element are 9.2  $\Omega$  between pins 1 and 3 (heating element), 54  $\Omega$  between pins 2 and 4 (sensor) at 23°F (73°C) — Fig. 2. If the measured values are outside this range, replace the heating element.

(No. A1507 24V-60W heating element for Hakko 817)

1. Unplug the cord.
2. Remove the nut, element cover and nozzle — Fig. 9.
3. Remove the screws securing the heating element to the housing — Fig. 9.
4. Remove the screws securing the housing and separate the housing — Fig. 9.
5. Remove the packing — Fig. 10.
6. Detach the terminal — Fig. 10.
7. Remove the old heating element and replace it with a new one — Fig. 10.
8. Reassemble the unit.

**CAUTION:**

Be sure to place the packing to prevent air escaping. Failure so to do will cause a loss in suction. Never set the nozzle temperature above the maximum temperature. It will cause problems.

**D. SOLDERING IRON TEMPERATURE ADJUSTMENTS**

SOLDERING TEMPERATURE ADJUSTMENT: (SEE PROCEDURE ON PAGE 7 OF INSTRUCTION MANUAL)

SOLDERING STATION CALIBRATION: (SEE PROCEDURE ON PAGE 16 OF INSTRUCTION MANUAL)

HEATER ERROR TOLERANCE ADJUSTMENT: (SEE PROCEDURE ON PAGE 17 OF INSTRUCTION MANUAL)

**E. DESOLDERING STATION MAINTENANCE AND REPAIR**

CLEANING NOZZLE AND HEATING ELEMENT: (SEE PROCEDURE ON PAGE 11&12 OF INSTRUCTION MANUAL)

CHECKING FILTERS: (SEE PROCEDURE ON PAGE 12 OF INSTRUCTION MANUAL)

CHECKING 807/817 SWITCH:

- Remove desoldering iron/gun cord from 703B.
- Press the switch, and measure resistance between pins 1 and 6 of the cord connector.
- The value should be 0.
- If the cord is good, replace the switch in the handpiece.

PUMP MAINTENANCE (SEE PROCEDURE ON PAGE 14 OF INSTRUCTION MANUAL).

**F. TESTING THE IRON CORD**

SOLDERING IRONS:

TEST METHOD 1

1. Turn the unit on.
2. Set the temperature to 480°C (899°F).
3. Without waiting for the iron to reach the set temperature, wiggle and kink the cord at various points along the length of the cord, including in the strain relief area at the base of the iron handle. If the heater lamp flickers, the cord is broken and should be replaced.

**CAUTION:**

The heater lamp will flicker if the iron temperature is allowed to reach the set temperature. Before replacing the cord, be sure that this is not the reason for the flickering.



## TEST METHOD 2

Check the resistance between each pin on the connecting plug and its associated wire on the terminal board insided the handle. (See the chart below.)

All measured values should be 0  $\Omega$ . If any value is greater than 0  $\Omega$  is  $\infty$ , replace the cord.

Pin Number	Wire Color	Resistance Value
1	Red	0 $\Omega$
2	Blue	0 $\Omega$
3	Green	0 $\Omega$
4	White	0 $\Omega$
5	Black	0 $\Omega$

## REPLACING THE IRON CORD

### **CAUTION:**

It is very important that these connections be soldered well. Poor solder joint could cause the unit to fail.

1. Undo the metal grip at the tabs.
2. Desolder the black and white heater leads.
3. Desolder the blue and red sensor leads.
4. Insert the new cord into the metal grip and bend the tabs over.
5. Insert the black and white heater leads and the blue and red heater leads through the holes in the fiberboard.
6. Solder these wires to the terminal board.

### DESOLDERING IRON:

Check the desoldering iron/gun cord. If it is broken, replace it with a new one. The method of checking the cord is same as soldering iron except for the following pin No. and color of the wire.

Pin 1 — Black  
Pin 2 — White  
Pin 3 — Red  
Pin 4 — White  
Pin 5 — Green  
Pin 6 — Blue

### **CAUTION:**

There are two white wires. Check another combination if the first one is not 0.

## G. REPLACING FUSE

### IF THE FUSE BLOWS AGAIN:

1. Check the heating element leads of 907 iron. Twisted heating element leads may cause short-circuit and fuse blowout. Also, check the heating element lead of 807/817.
2. Test the printed wiring board. (See procedure A)
3. Check the transformer. (See Table II)

Dec. 2002

MA00043JU021201

---