

HAKKO 470B

DESOLDERING TOOL

Desoldering Tool

Instruction Manual

Thank you for purchasing the Hakko 470B desoldering Tool.

Please read the manual before using the Hakko 470B. Store the manual in a safe, easily accessible place for future reference.

 **CAUTION** : Remove the pump securing screw (M4 x 25 marked red) from the bottom of the station.
Failure to do so may result in serious problems.

Table of Contents

Packing List	1
Safety Instructions	2
Part Names (Desoldering Gun).....	3
(Station).....	4
Operation (Preparation- Assembly and Connection)....	5 · 6
(Desoldering)	7 · 8
(Cleaning during Operation)	9
(Problems during Desoldering) (Post-operation Maintenance)...	10
(Troubleshooting Guide).....	11
Maintenance (Desoldering Gun)	12~14
(Station).....	15 · 16
Replacement Parts (Replacing Heating Element)....	17 · 18
Parts List (Station).....	19 · 20
(Desoldering Gun).....	21
Specifications, Wiring	22

Packing List

Please check to make sure that all the items listed below are included in the Hakko 470B package.

Station	1	Ceramic Paper Filter (S).....	2
Desoldering Gun	1	Ceramic Paper Filter (L).....	4
Iron Holder Base	1	Spring Filter.....	3
Spring Iron Holder	1	Cleaning Pin (for $\phi 1.0\text{mm}$ [0.04 in.] nozzle)	1
Cleaning Sponge.....	1	Cleaning Pin (for Heating Element).....	1
Filter Pipe.....	1	Cleaning Pin Holder	1
		Cleaning Drill (for $\phi 1.0\text{mm}$ [0.04 in.] nozzle)	1
		Silicone Grease.....	1
		Spanner.....	1
		Instruction Manual.....	1

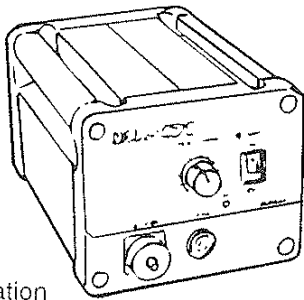

Station

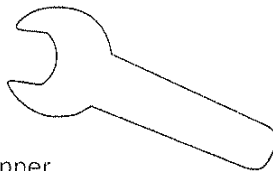

Spanner



Iron Holder Base

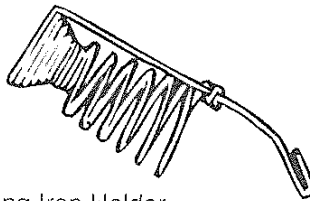

Spring Iron Holder

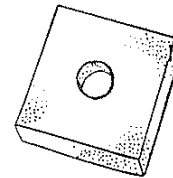

Cleaning Sponge

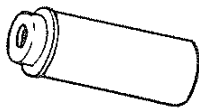

Filter Pipe

Ceramic Paper Filter (S)

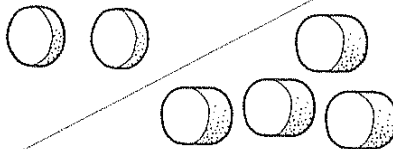

Ceramic Paper Filter (L)

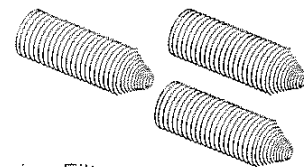

Spring Filter



Cleaning Pin for $\phi 1.0$ mm (0.04 in.) Nozzle

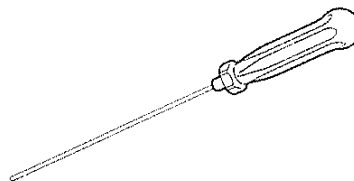

Cleaning Pin for Heating Element

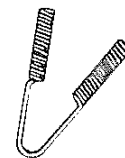

Cleaning Pin Holder

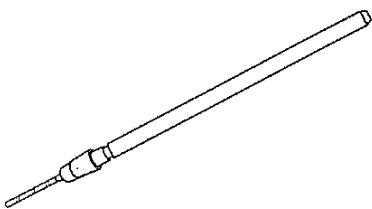

Cleaning Drill for $\phi 1.0$ mm (0.04 in.) Nozzle

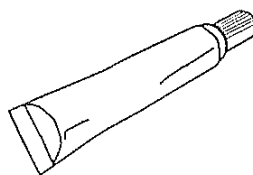

Silicone Grease

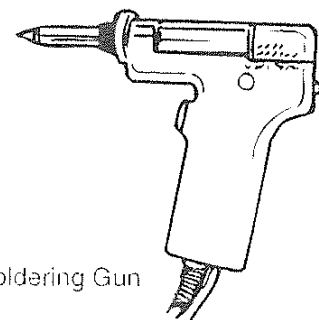



Desoldering Gun

Safety Instructions

WARNING

Warnings, cautions are placed at critical points in this manual to direct the operator's attention to significant items. They are defined as follows:

-  **WARNING:** Failure to comply with a WARNING may result in serious injury or death.
-  **CAUTION :** Failure to comply with a CAUTION may result in injury to the operator, or damage to the items involved.
For your own safety, be sure to comply with these precautions.

CAUTION

Remove the pump securing screw (M4 x 25 marked red) from the bottom of the station.
Failure to do so may result in serious problems.

When the power is ON, the nozzle temperature is between 380°C and 480°C (716°F and 896°F).
Since mishandling may lead to burns or fire, be sure to comply with the following precautions.

- Do not touch the metal parts near the nozzle, nearby plastic parts and the spring iron holder .
- Do not use the product near flammable items.
- Advise those in the work area that the unit can reach very high temperatures and should be considered potentially dangerous.
- Turn the power OFF when no longer using the Hakko 470B or when leaving it unattended.
- Before replacing parts or storing the unit, allow the unit to cool and then turn the power OFF.

To prevent accidents and failures, be sure to take the following precautions:

- Do not use the unit for applications other than desoldering.
- Do not rap the desoldering gun against the work bench to shake off residual solder, or otherwise subject the iron to severe shocks.
- Do not modify the unit.
- Use only genuine Hakko replacement parts.
- Do not wet the unit or use the unit with wet hands.
- Set the ceramic paper filter (S) for the filter retainer (station), and the ceramic paper filter (L) for the filter pipe (gun).
- Maintain the desoldering gun and the station.
- While using the unit, don't do anything which may cause bodily harm or physical damage.

Part Names (Refer to p.19,20,21 for part nos.)

● Desoldering Gun

Nozzle

Transmits heat for melting solder.
Entrance for melted solder.
Expendable part

Filter Pipe

Insert the ceramic paper filter (L) (No. A1033).
Contains filters which arrest melted solder and flux.
Filter are expendable parts.

Back Holder Assembly

Secures the filter pipe.

Heating Element

Inside requires cleaning.

Trigger

Squeeze to start extraction.
Do not pull the trigger before fully heating the nozzle.

Release Knob

Push down to remove the filter pipe.

Indicator

Indicates when nozzle and heating element need cleaning and when filters need replacing.

Hose

Connects to the vacuum outlet cap (station).

Cord Assembly

Connects to the receptacle (station).

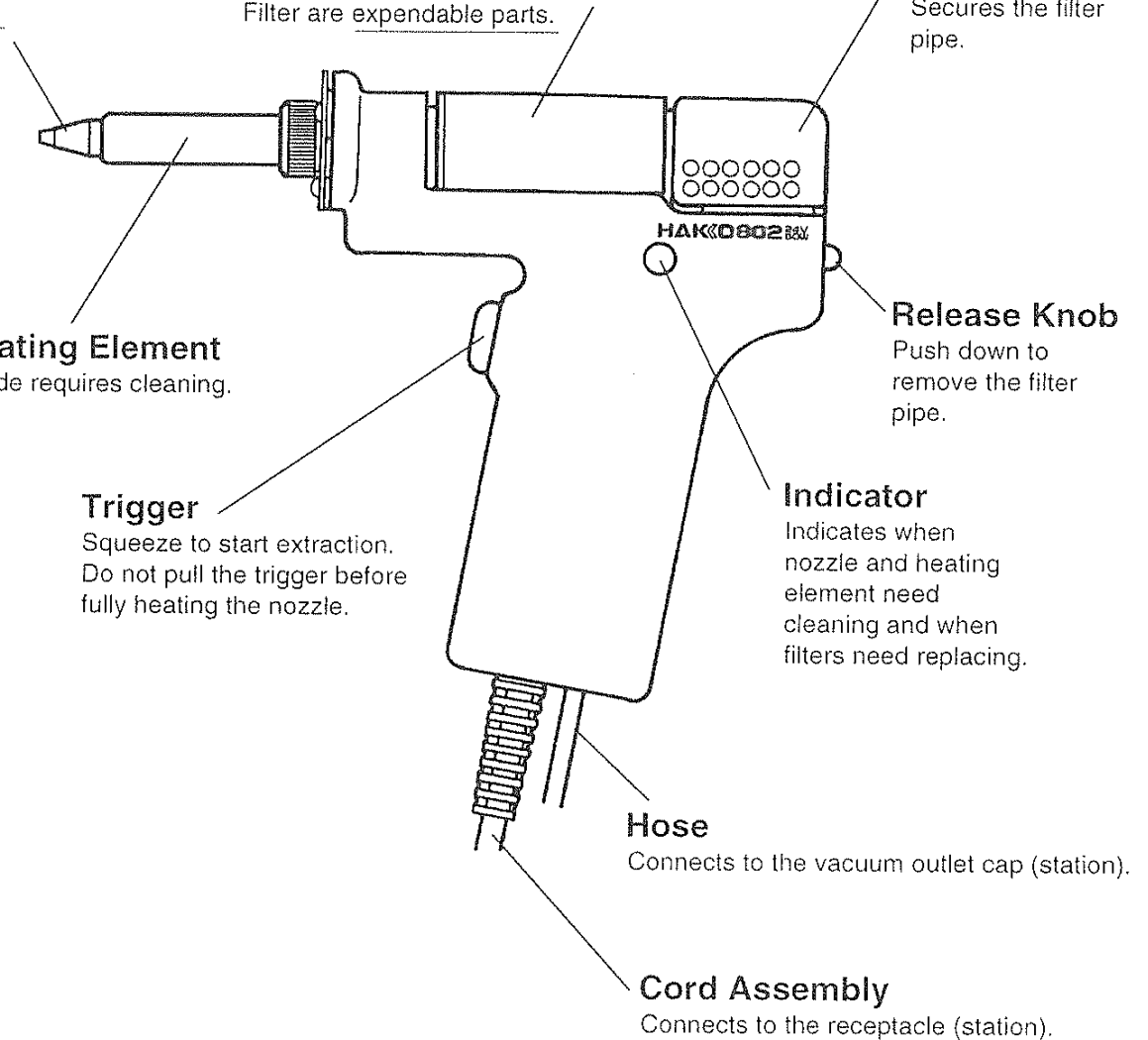

● Station

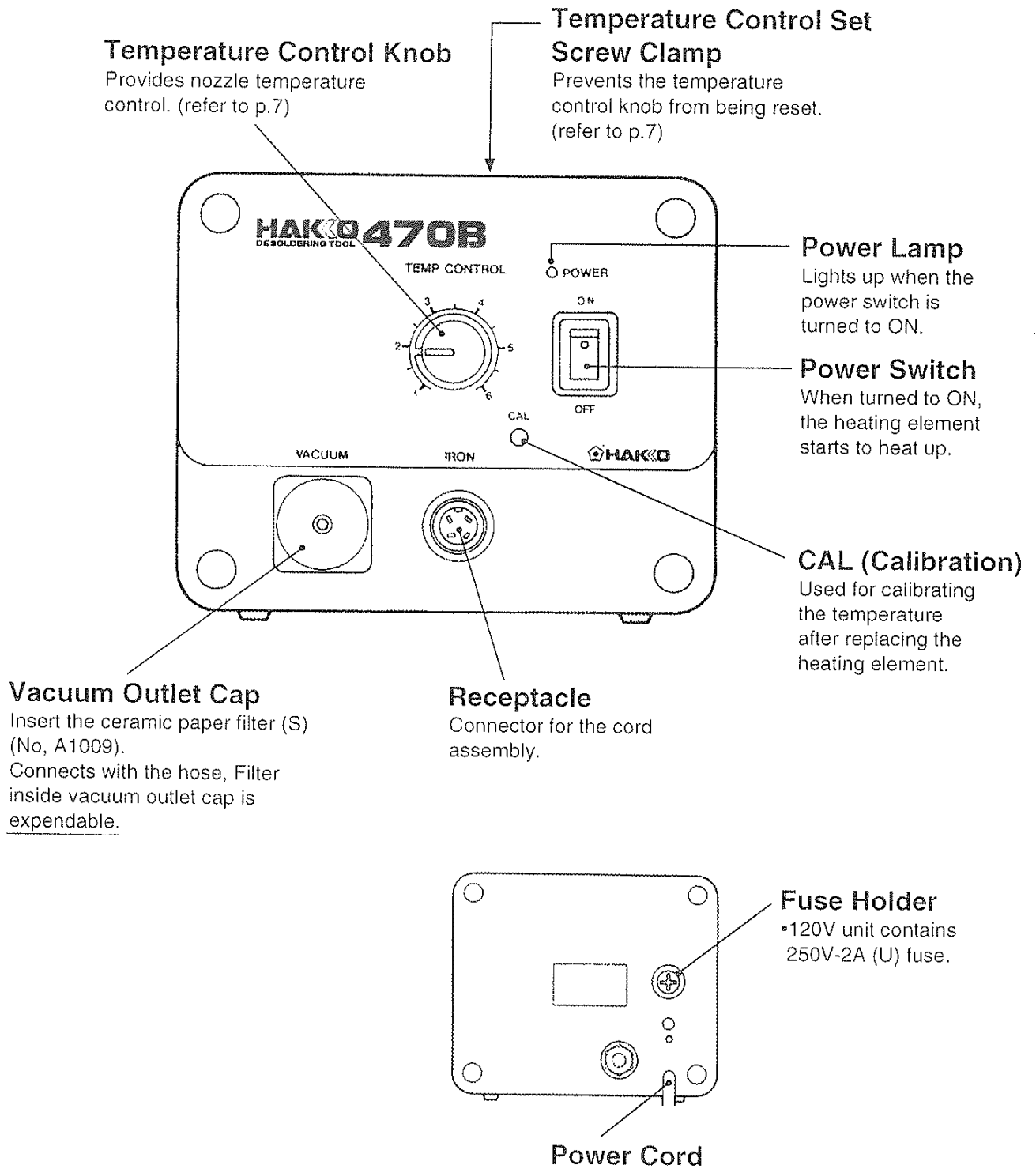

Operation

Preparation–Assembly and Connection

Assemble the Hakko 470B on a flat surface.

- ① Remove the pump securing screw (M 4 x 25 marked red) from the bottom of the station.

- ② Assemble the iron holder.

- Set the spring iron holder and cleaning pin holder in the iron holder base.
- Dampen the cleaning sponge with water and then squeeze it dry.

⚠ CAUTION

The sponge is compressed. It will swell when moistened with water. Be sure to dampen the sponge with water before use. Be sure to remove the round portion of the sponge.

- ③ Insert the desoldering gun and cleaning pins.

- Fully insert the desoldering gun into the spring iron holder.

⚠ CAUTION

The spring iron holder becomes extremely hot during operation of the desoldering gun. Do not touch the spring iron holder during and immediately after using the gun.

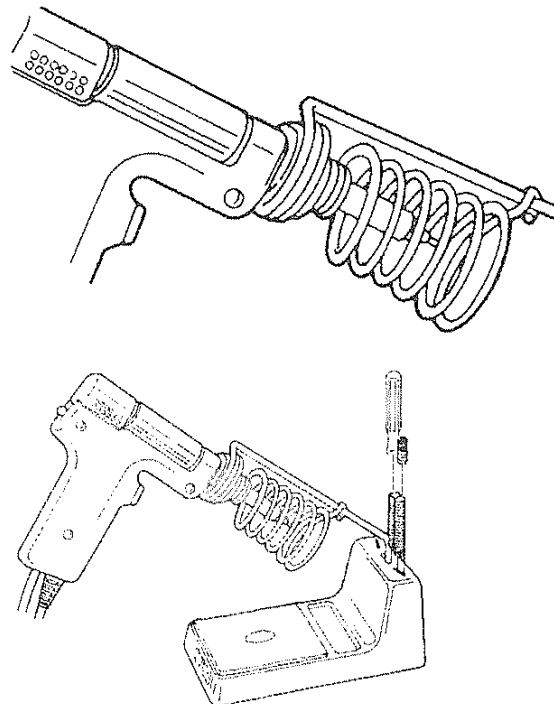
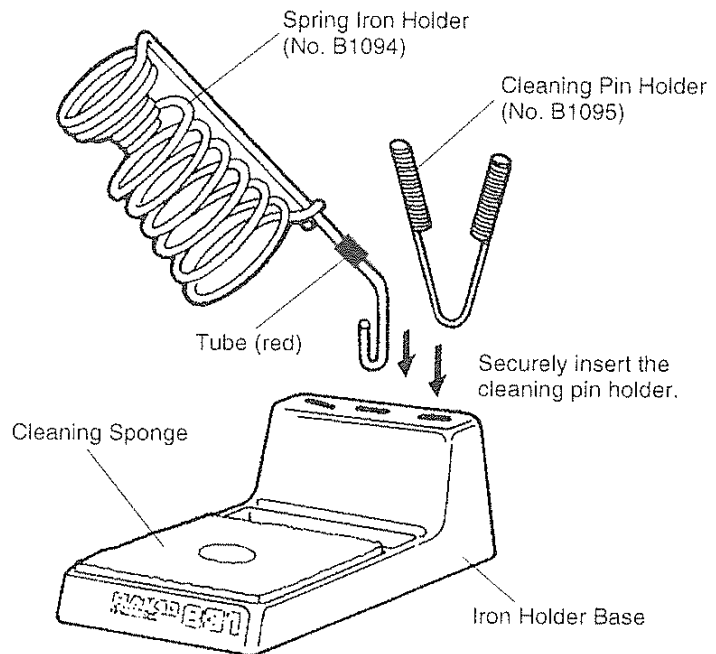

④ Connections

⚠ CAUTION

Be sure to turn the power switch off before connecting or disconnecting the cord assembly and the power plug. Failure to do so may damage the P.W.B.

- Connect the cord assembly to the receptacle (marked "IRON").
- Connect the hose to the vacuum outlet cap (marked "VACUUM").

IRON

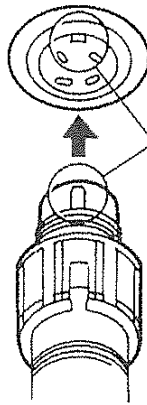

Insert the cord assembly by keying the plug to the key on the receptacle.

IRON

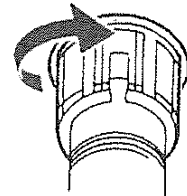

Secure the plug by turning it clockwise.

VACUUM

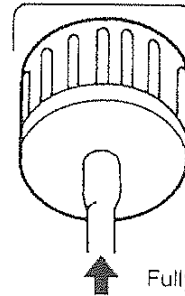

Fully insert the hose over the vacuum outlet cap.

⑤ Power switch

- Confirm that the power switch is set in the OFF position, then connect the power plug to the power source.

⚠ CAUTION

The entire unit is constructed of conductive materials. Always ground the unit.

- Turn the power switch to ON. The power lamp should light up.
- The nozzle begins to heat up as soon as the power switch is turned to ON.

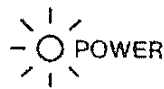

ON

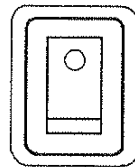

OFF

The power lamp lights up.

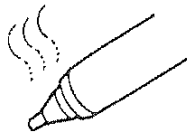

The nozzle heats up.

The power lamp doesn't light up.

1. Is the power cord properly connected?
2. Is the fuse blown?

The nozzle doesn't heat up.

1. Is the cord assembly properly connected?
2. Is the heating element broken?

- ⑥ After turning the power switch to ON, wait three (3) minutes before beginning desoldering operations.

⚠ CAUTION : The desoldering gun must be placed in the iron holder when not in use.

Operation

Desoldering

After turning the power switch to ON, wait three (3) minutes before beginning desoldering operations.

① Set the temperature.

⚠ CAUTION

Always set the temperature to as low as possible for the work being done.

- To more precisely set the temperature, measure the temperature at the nozzle using a soldering iron thermometer and adjust the temperature control knob accordingly.

We recommend the Hakko 191 thermometer or Hakko 192 soldering tester for measuring the nozzle temperature.

- The temperature control knob can be secured by tightening the temperature control set screw clamp ("+" screw) at the top of the Hakko 470B unit.

② Clean the tip of the nozzle.

- Keep the solder-plated section of the nozzle a shiny white by coating it with a small amount of solder.

If the tip of the nozzle is coated with oxide, the nozzle's heat conductivity will be lowered. Coating the tip with a small amount of fresh solder ensures maximum heat conductivity.

The temperature can be adjusted between 380°C and 480°C (716°F and 896°F) with temperature control knob.

Please refer to the chart below, and adjust the temperature control knob.

knob	P.W.B.
1 — 2	Single-sided P.W.B.
3 — 4	Through-hole P.W.B.
5 — 6	Multilayer P.W.B.

⚠ CAUTION

Never insert the cleaning pin in the hole of temp. control set screw clamp, as this may result in damage to the unit.



Secure the temperature control set screw clamp with a cross point screwdriver.

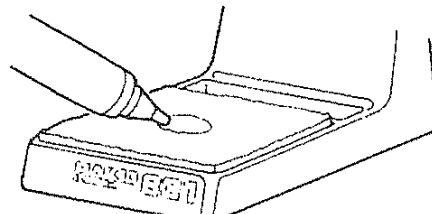
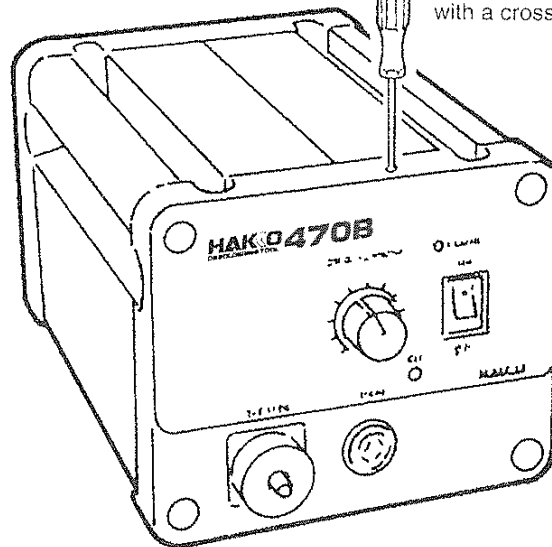

Wipe away any oxide or old solder from the nozzle using the hole in the center of the sponge.

③ Melt the solder.

- Apply the nozzle to the soldered part and melt the solder.

⚠ CAUTION

Never allow the nozzle to touch the board itself.

- Confirm that the solder is melted.

⚠ CAUTION

To confirm that all the solder is melted, observe the inside of the hole and the backside of the P.W.B. If this is difficult to do, try slowly moving the lead with the nozzle—if the lead moves, the solder is melted.

⚠ CAUTION

Never move the lead by force. If it doesn't move easily, the solder isn't yet fully melted.

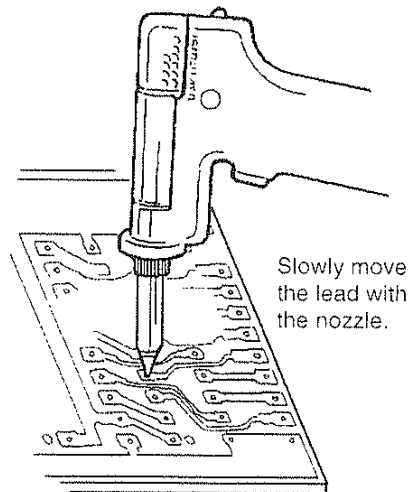
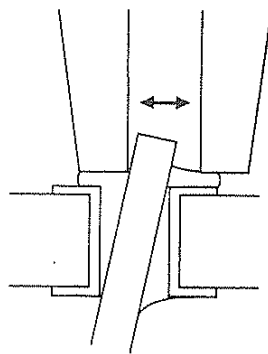
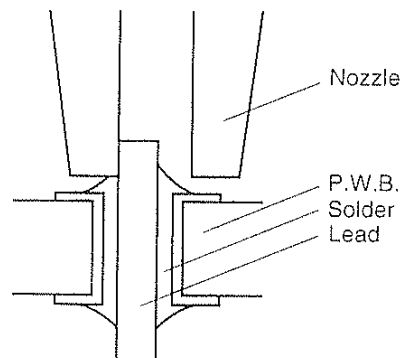

④ Extract the solder.

- After confirming that the solder is completely melted, Extract the solder by squeezing the trigger on the gun.

⚠ CAUTION

Never leave any solder remaining inside the hole in the P.W.B.

- After fully extracting all the solder, cool the soldering junction in order to prevent it from becoming resoldered.

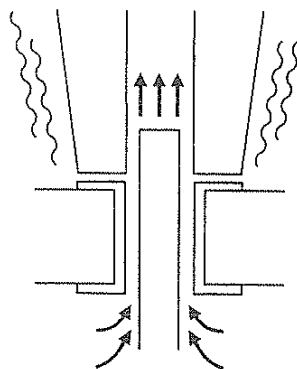

Extract the solder by slowly moving the lead back and forth with the tip of the nozzle.

⑤ Problems during desoldering

- If solder remains, resolder the component and repeat the desoldering process.

Operation

Heated solder and flux can cause oxides to form and adhere to the nozzle and the inside of the heating element. These oxides not only lower the heat conductivity, but can also clog the nozzle and heating element, resulting in a drop in suction efficiency. Should there be a noticeable drop in suction efficiency during operation, replace the filter and clean the nozzle and heating element with the provided cleaning pin.

Cleaning during Operation

① Observing the indicator

While looking at the indicator and with the hole of the nozzle open, pull the trigger and look at the indicator. If it is red, clean the nozzle and heating element, empty the filter pipe, and replace the filters. If the indicator is blue, cleaning is not necessary and operations can be resumed.

⚠ CAUTION



The indicator will not operate accurately if the hole of the nozzle is closed or if the solder in the hole of the P.W.B. is not melted.

⚠ CAUTION

The indicator on the Hakko 471 reads in a different way. For instructions on the reading the Hakko 471 indicator, please refer to the Hakko 471 instruction manual.

② Replacing the filter

Replace the filter as shown ① — ③. During operation, the filter pipe is very hot. Wait until the filter pipe is cool before replacing the filter. We recommend keeping a second filter pipe containing new filters handy, and replacing the installed filter pipe with this backup filter pipe.

Normal	Abnormal	Solution
		If the indicator is more than half red, replace the filter and clean the nozzle and the inside of the heating element. (refer to p.12 Maintenance of the Desoldering Gun)
Blue or slight amount of red can be seen.	More than half of the indicator is red.	

⚠ CAUTION : If there is a noticeable drop in suction efficiency, clean the nozzle and heating element with the cleaning pin.

③ Replace the entire filter pipe with the provided backup filter pipe.

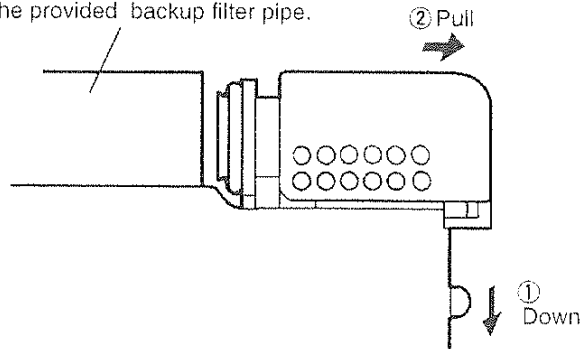

Problems during Desoldering

- A. The solder in the junction is not sufficiently melted.
- B. Suction power is dropping.

A. The solder in the junction is not sufficiently melted.

● Temperature is not high enough.

The following parts require a greater heat capacity to desolder:

- Multilayer P.W.B.s, power supplies, ground planes in through-hole P.W.B.s, high-capacity transistors, triacs with heat radiation fins, tuner P.W.B. ground wires, and large-scale transformer terminals.

Use a preheating oven or heating gun to heat the P.W.B. to a temperature that won't damage the board or its components [between 70°C (160°F) and 80°C (180°F)], then desolder. Do not increase the temperature of the gun by recalibration as this may damage the P.W.B. and its components.

● Nozzle is worn out.

- When the nozzle begins to wear out, the heating efficiency begins to decline. Check the nozzle. If the solder plating is damaged, or the nozzle is eroded, replace the nozzle. (refer to p.12)

B. Suction power is dropping.

- Replace the filters, and clean the nozzle and the inside of the heating element. (refer to p.12~16, Maintenance of Desoldering Gun and Station)

● Air is leaking from the vacuum system.

Air leakage cannot be determined from the indicator. Check the air-tightness of the following parts and replace any that are worn.

- | | |
|----------------------------------------------------|------------------------------|
| a. Contact point of the nozzle and heating element | c. O-ring in the back holder |
| b. Front holder and nearby parts | d. Hose |
| | e. Vacuum outlet cap |
| | f. Packing and nearby parts |

Post-operation Maintenance

To ensure a long service life, always perform the following maintenance procedures immediately after using the Hakko 470B unit.

- Remove all solder from the inside of the nozzle and heating element.
- Clean the tip of the nozzle with the cleaning sponge, then coat the tip with a fresh layer of solder to protect the solder plating.

Troubleshooting Guide

⚠ WARNING : If the power cord is damaged, it must be replaced by the manufacturer, its service agent or similarity qualified person in order to avoid personal injury or damage to the unit.

● Power lamp does not light up.

• Is the power cord plugged in correctly?

Securely insert the power cord into the power supply.

• Is the fuse blown?

Investigate why the fuse blew and then replace the fuse. If the cause can not be determined, replace the fuse.

If the fuse blows again, send the unit in for repair.

Example Is the inside of the gun short-circuited?

● Pump does not operate.

• Is the cord assembly properly connected?

Reconnect the cord assembly. (refer to p.6)

• Is the nozzle or hole in the heating element clogged?

Clean it. (refer to p.12)

● Solder is not being absorbed.

• Is the spring filter full of solder?

Replace it with a new one. (refer to p.13)

• Is the ceramic filter hardened?

Replace it with a new one.

• Is there a vacuum leak?

Check the connections and replace any worn parts. (refer to p.10)

● The nozzle does not heat up.

• Is the desoldering gun cord assembly properly connected?

Reconnect it. (refer to p.6)

• Is the heating element damaged?

Replace it. (refer to p.17)

Note : When repairs are needed please send both the desoldering gun and the station to your sales agent.

Maintenance (Desoldering Gun)

Properly maintained, the Hakko 470B desoldering gun should provide years of good service. Efficient desoldering depends upon the temperature, and the quality and quantity of the solder and flux. Perform the following service procedures as dictated by the conditions of the gun's usage.

⚠ WARNING : Since the desoldering gun can reach a very high temperature, please work carefully. Except when cleaning the nozzle and heating element, always turn the power switch off and disconnect the power plug before performing any maintenance procedure.

Servicing the Desoldering Gun

⚠ CAUTION

The desoldering gun will be extremely hot. During maintenance, please wear gloves and work carefully.

① Inspect and clean the nozzle.

- Plug in the power cord, turn the power switch on and let the nozzle heat up.
- Clean out the hole of the nozzle with the nozzle cleaning pin.

⚠ CAUTION

The cleaning pin will not pass through the nozzle until the solder inside the nozzle is completely melted.

- If the cleaning pin does not pass through the hole in the nozzle, clean with the cleaning drill.
- Check the condition of the solder plating on the tip of the nozzle.
- If it is slightly worn, recoat the tip with fresh solder to prevent oxidation.
- Check the condition of the surface and inside hole of the nozzle.
- If either is worn or eroded, or the inside diameter seems unusually wide, replace the nozzle.

⚠ CAUTION

The inside hole and the surface of the nozzle is plated with a special alloy. Should this alloy become eroded by high-temperature solder, the nozzle will not be able to maintain the proper temperature.

Cleaning with the nozzle cleaning pin.

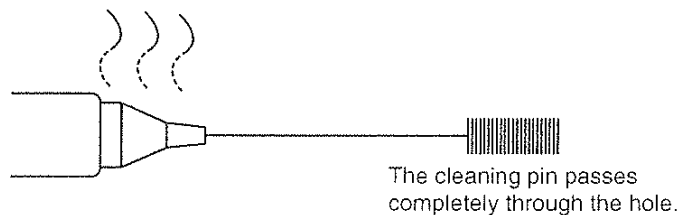

Cleaning with the cleaning drill.

• Before cleaning

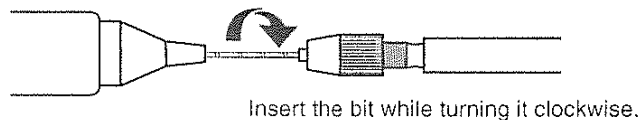

• After cleaning

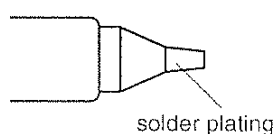
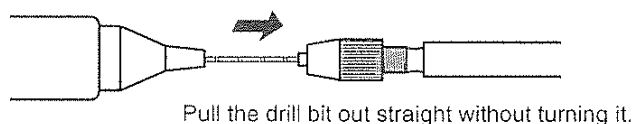

⚠ CAUTION

If the cleaning drill is forced into the nozzle, the drill bit could break or be damaged.

⚠ CAUTION

Please use the proper sized cleaning pin or cleaning drill for the nozzle diameter.

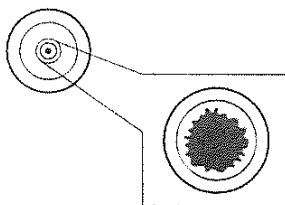

Diameter of hole is widened through erosion.

Note

Unfortunately, it is often difficult to observe this condition. Therefore, if desoldering efficiency goes down and all other parts appear to be OK, the nozzle is probably eroded and should be replaced.

② **Disassemble the heating element.**

⚠ CAUTION

The heating element is very hot during operation.

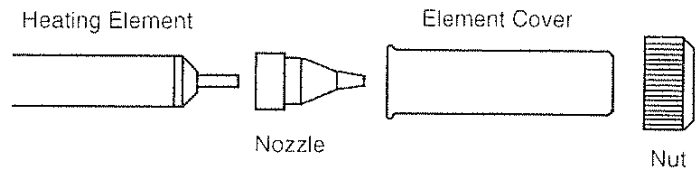

Remove the nut with the attached spanner.

③ **Clean out the hole in the heating element with the provided cleaning pin.**

⚠ CAUTION

Be sure the solder in the hole in the heating element is completely heated, before cleaning the hole.

- If the cleaning pin cannot pass through the hole, replace the heating element.
- Turn the power off after cleaning.

Scrape away all oxidation from the hole in the heating element until the cleaning pin passes cleanly through the hole.

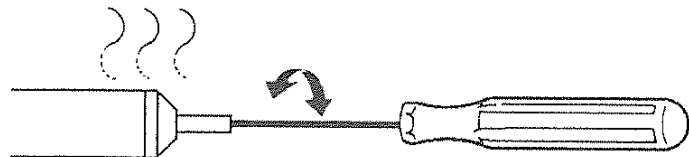

The cleaning pin passes cleanly and completely through the hole.

④ **Replace the filters.**

- Turn the power switch OFF.
- When the filter pipe is cool to the touch, push down the release knob at the back of the gun and remove the filter pipe.

⚠ CAUTION

The filter pipe is very hot.

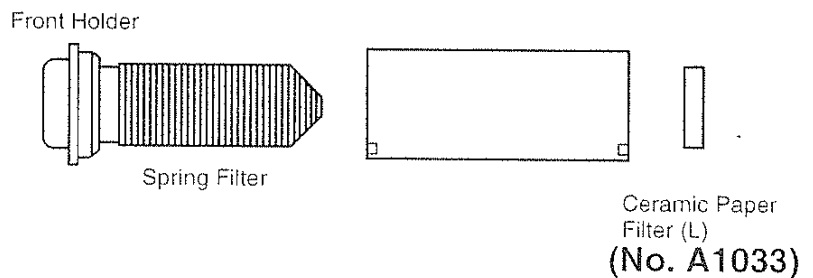

- Examine the front holder.

Replace
Stiff and cracked.

- Examine the spring filter.

Replace
Solder is collected in two-thirds of the spring filter.

- Examine the ceramic paper filter (L). (No. A1033)

Replace
Ceramic paper filter is stiff with flux and solder.

⑤ **Secure the filters.**

- Attach the spring filter to the front holder.
- Attach the front holder to the filter pipe.

⚠ CAUTION

Be sure the front holder is correctly aligned.

⚠ CAUTION

Use the ceramic paper filter (L) for the filter pipe (gun). Using of the ceramic paper filter (S) in the filter pipe may cause to break or the power to drop.

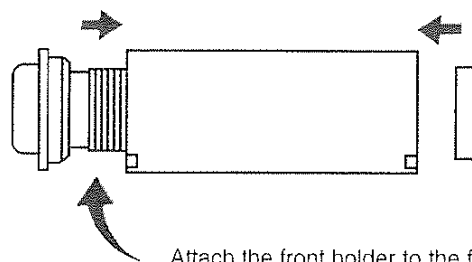
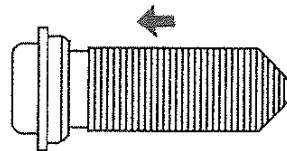

Ceramic Paper Filter (L)
(No. A1033)

Attach the front holder to the filter pipe so that it does not leak air.

Firmly press the back holder assembly into the filter pipe in order to properly seat the O-ring against the pipe.

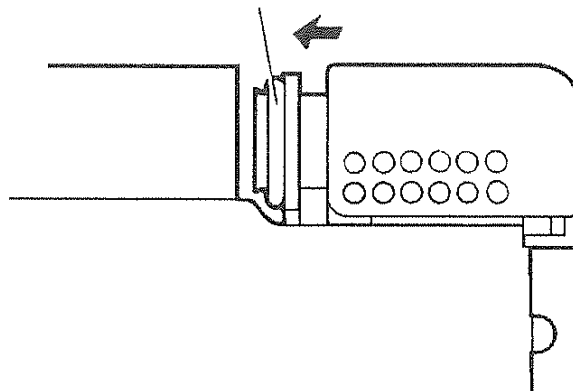

⑥ **Assemble the heating element.**

- Attach the nozzle and securely tighten the nut with the attached spanner.

⚠ CAUTION

If the nut is loose, air will leak and the temperature will drop.

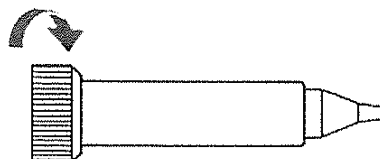

Maintenance (Station)

Cleaning the inside of the Filter Case

- ① **Replace the ceramic paper filter (No. A1009).**
Remove the ceramic paper filter and inspect it. If it is stiff with flux, replace it.

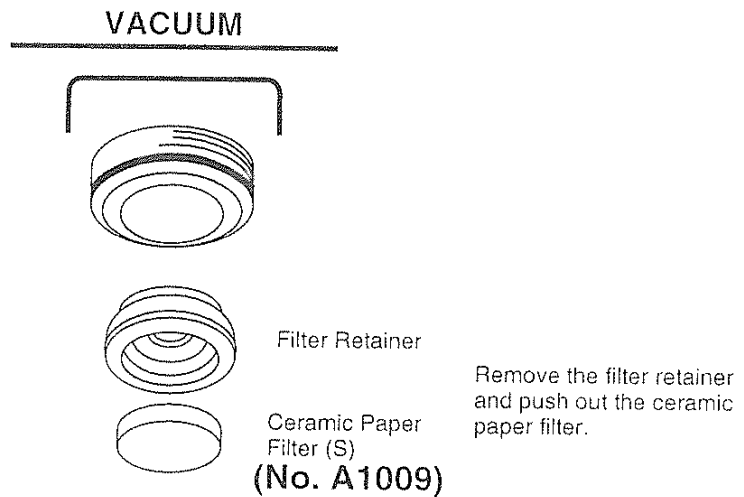

- ② **Reassemble the filter case.**

⚠ CAUTION

Set the ceramic paper filter (S) for the filter retainer (station).
Using the ceramic paper filter (L) in the filter retainer may cause to break or the power to drop.

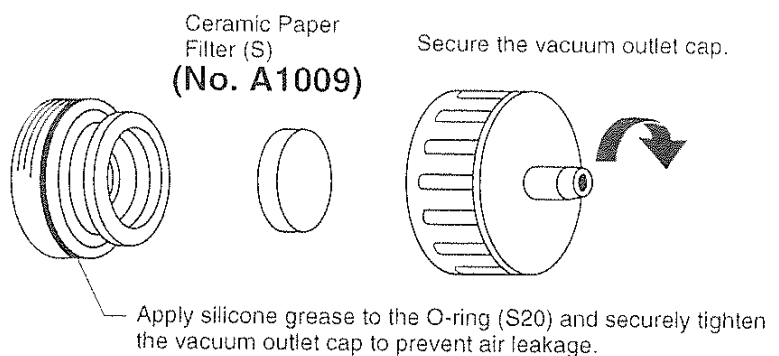

Cleaning the Pump

⚠ WARNING

Unplug the power cord before starting this procedure.

① Disassemble the pump heads.

- Remove the rear panel.
- Remove the cover.
- Remove the pump head from each side of the pump.

② Clean the pump head.

- Remove the valve plate and fixing plate.
- Remove any flux adhering to the plates.

⚠ CAUTION

If the fixing plate is difficult to remove, apply hot air to it to warm it up. Never use excessive force to remove the plate as it is easy to bend, and a bent plate will allow air to leak out and reduce solder vacuuming efficiency.

⚠ CAUTION

Clean the plates only with isopropyl alcohol or denatured alcohol.

Replace:

If the valve plate is bent or stiff, replace it.

- If the exhaust filter is dirty, replace it.

③ Assemble the pump heads.

Reassemble the valve plate and fixing plate.

⚠ CAUTION

When assembling the pump, be sure to check for air leaks.

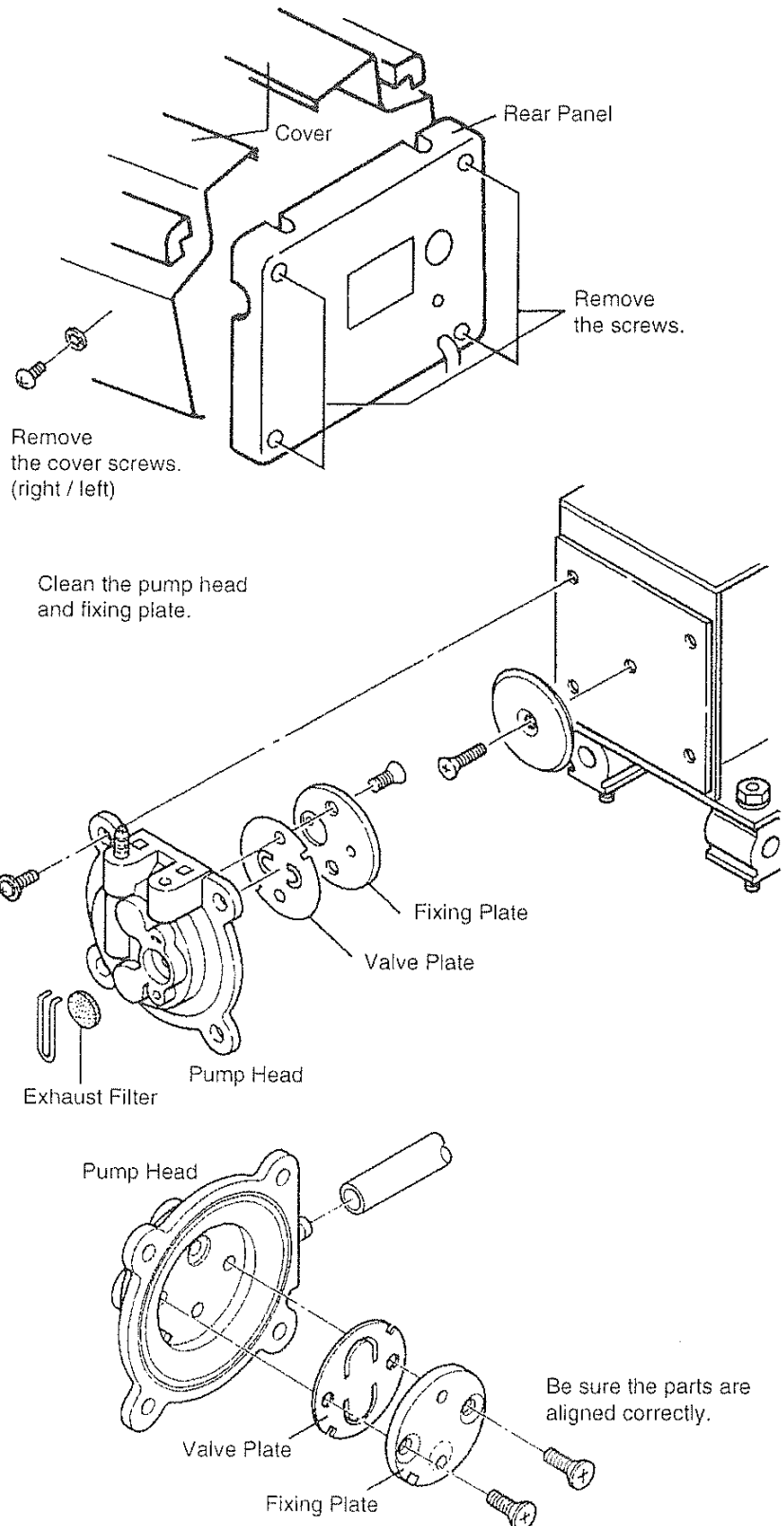

Replacement Parts

Replacing the Heating Element

⚠ CAUTION

Unplug the power cord before starting this procedure.

The resistance value of a working heating element is 2-4 Ω at 23°C (73°F). If the value you get is outside this range, replace the heating element.

① Disassemble the heating parts.

② Separate the housing.

③ Detach the terminal and remove the heating element.

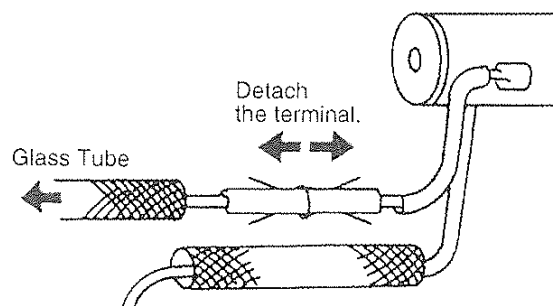
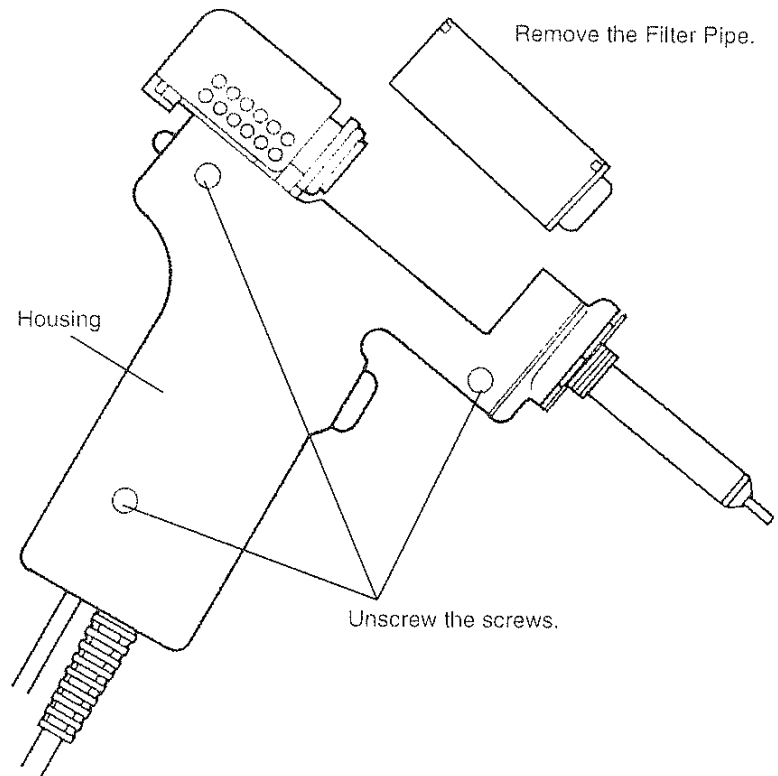
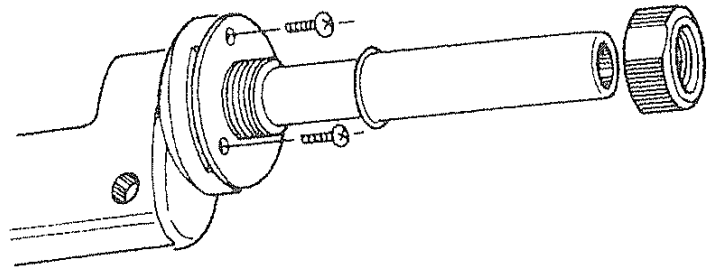

④ **Insert a new heating element and reassemble.**
(Heating element 24V-50W)

CAUTION

Before reassembling enclosure, make sure connectors are completely covered by the glass tube.

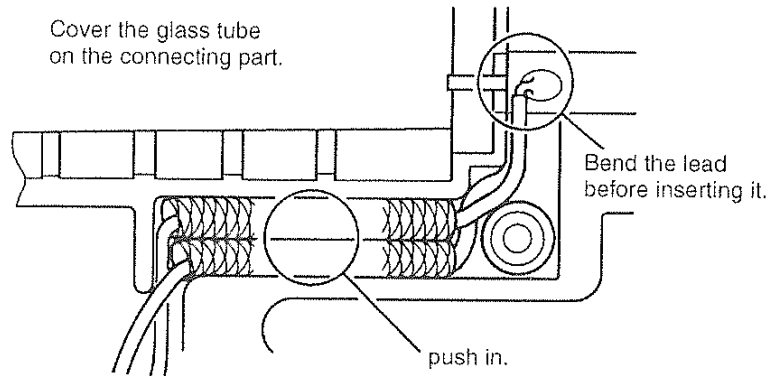

Position the leads in groove and press them into place. Be careful that the leads do not get caught in the housing.

⑤ **Recalibrate the temperature.**

The resistance of new heating element varies, resulting in variations in operating temperatures. It is necessary to recalibrate the temperature every time the heating element is replaced.

- Set the temperature control knob to 1 and allow the gun to warm up for three (3) minutes.
- Using a tip thermometer, adjust the temperature calibrator (marked "CAL") until the nozzle temperature reads 380°C(716°F).

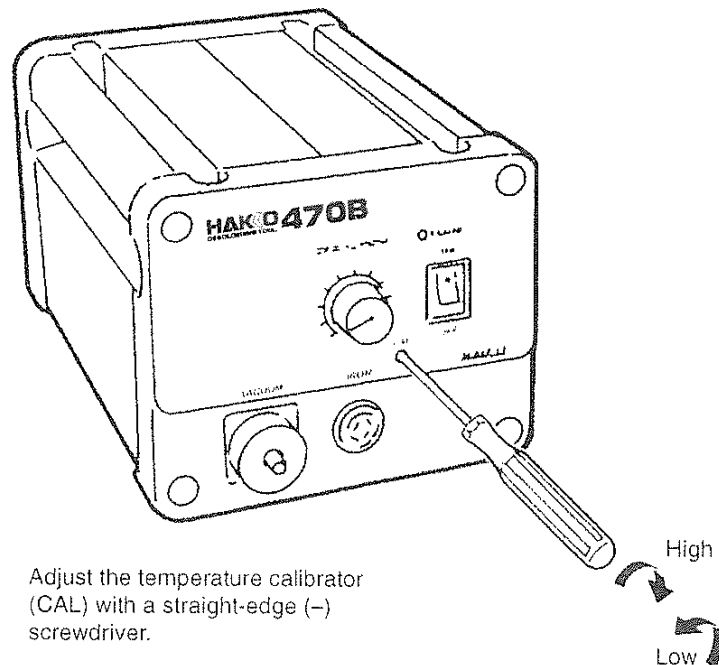

Parts List (Station)

Note: Spare or repair parts do not include mounting screws, if they are not listed on the description.
Screws must be ordered separately.

Item No.	Part No.	Part Name	Description
1	B1029	Vacuum outlet cap	
2	A1009	Ceramic paper filter (S)	10 pcs
3	B1063	Filter retainer	
4	B1031	Vacuum outlet retainer	With O-ring (S20) With screws
5	B1034	O-ring (S20)	
6	B1038	Cover for securing screw	Set of 4
7	B1036	Receptacle	
8	B1028	Knob	With screw
9	B2434	Front panel	With screws
10	B1093	Cover	One side
11	B1061	Handle	One side
12	B1044	Volume fixing	With screws
13	B2443	P.W.B.	With potentiometer

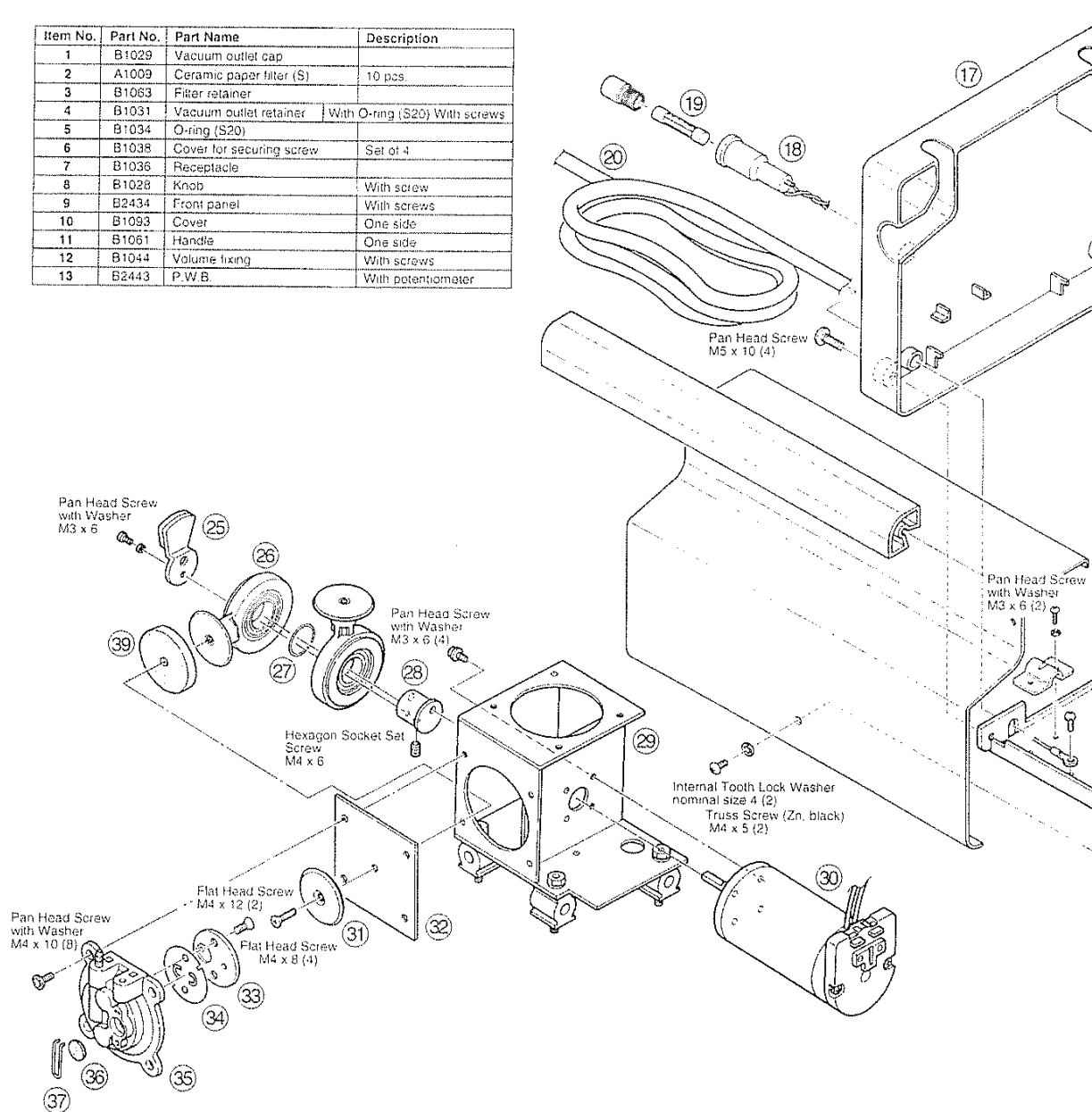

Item No.	Part No.	Part Name	Description
14	B2063	Hose assembly	
15	B2078	Transformer	120-24V
16	B2444	Pump assembly	
17	B2146	Rear panel	With rating seal
18	B1041	Fuse holder	With fuse
19	B1275	Fuse	250V-2A (U); 120V

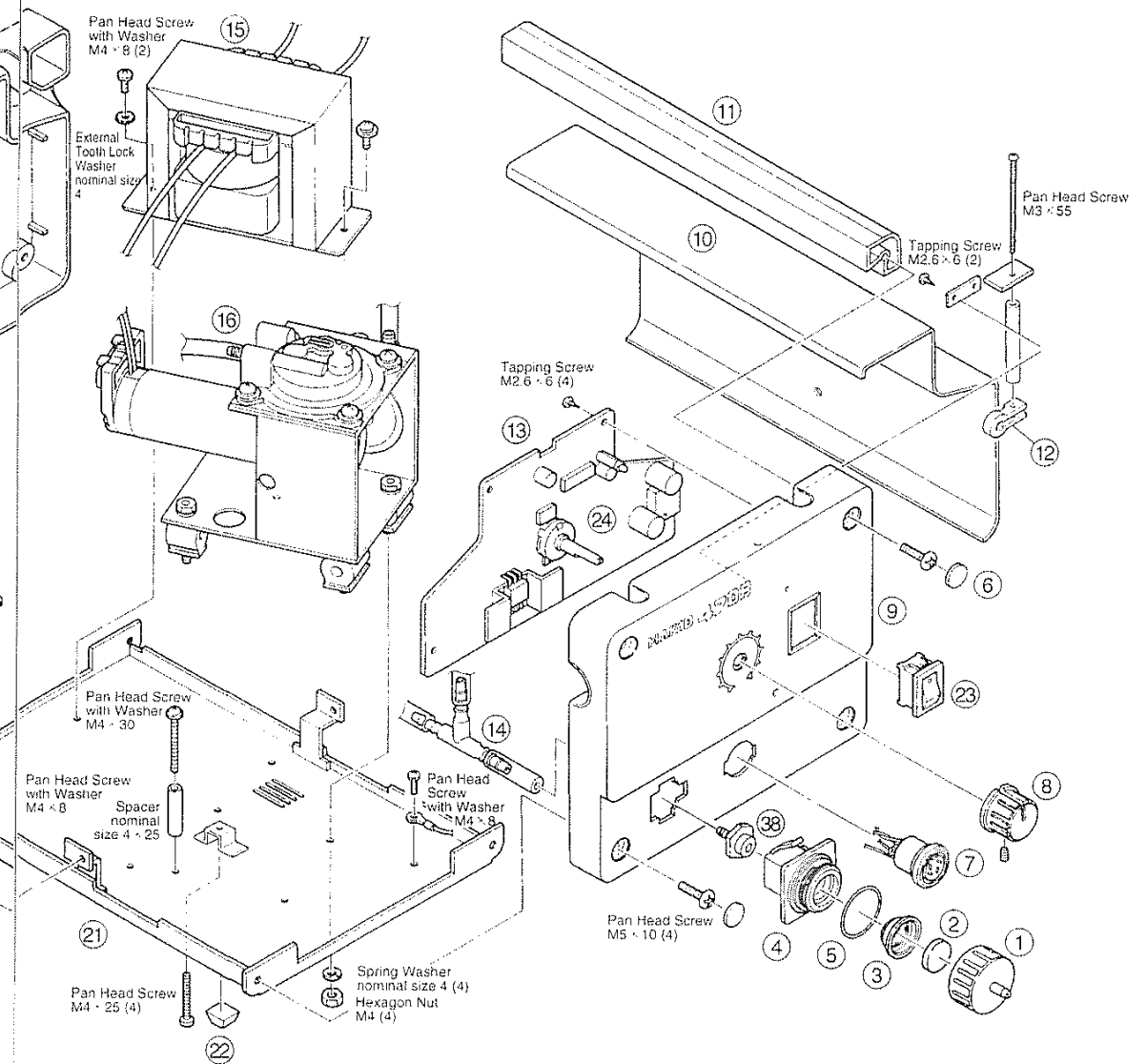

Item No.	Part No.	Part Name	Description
20	B2068	Power cord	3 core & american plug
21	B2445	Chassis	
22	B1037	Rubber stopper	Set of 4
23	B1084	Switch	
24	B1078	Potentiometer	
25	B1053	Balance weight	
26	B1312	Crank	With Bearing

Item No.	Part No.	Part Name	Description
27	B1057	Ring for bearing	
28	B2060	Crank shaft	With screw
29	B2059	Pump frame	
30	B2058	Motor	
31	B2085	Diaphragm setting plate	
32	A1013	Diaphragm	Set of 2 w/screws
33	B1056	Fixing plate	
34	A1014	Valve plate	Set of 2
35	B1050	Pump head	With screws
36	B1059	Exhaust filter	Set of 2
37	B1313	Filter retaining pin	
38	B1064	Filter case joint	
39	B2506	Damper	Set of 2

Parts List (Desoldering Gun)

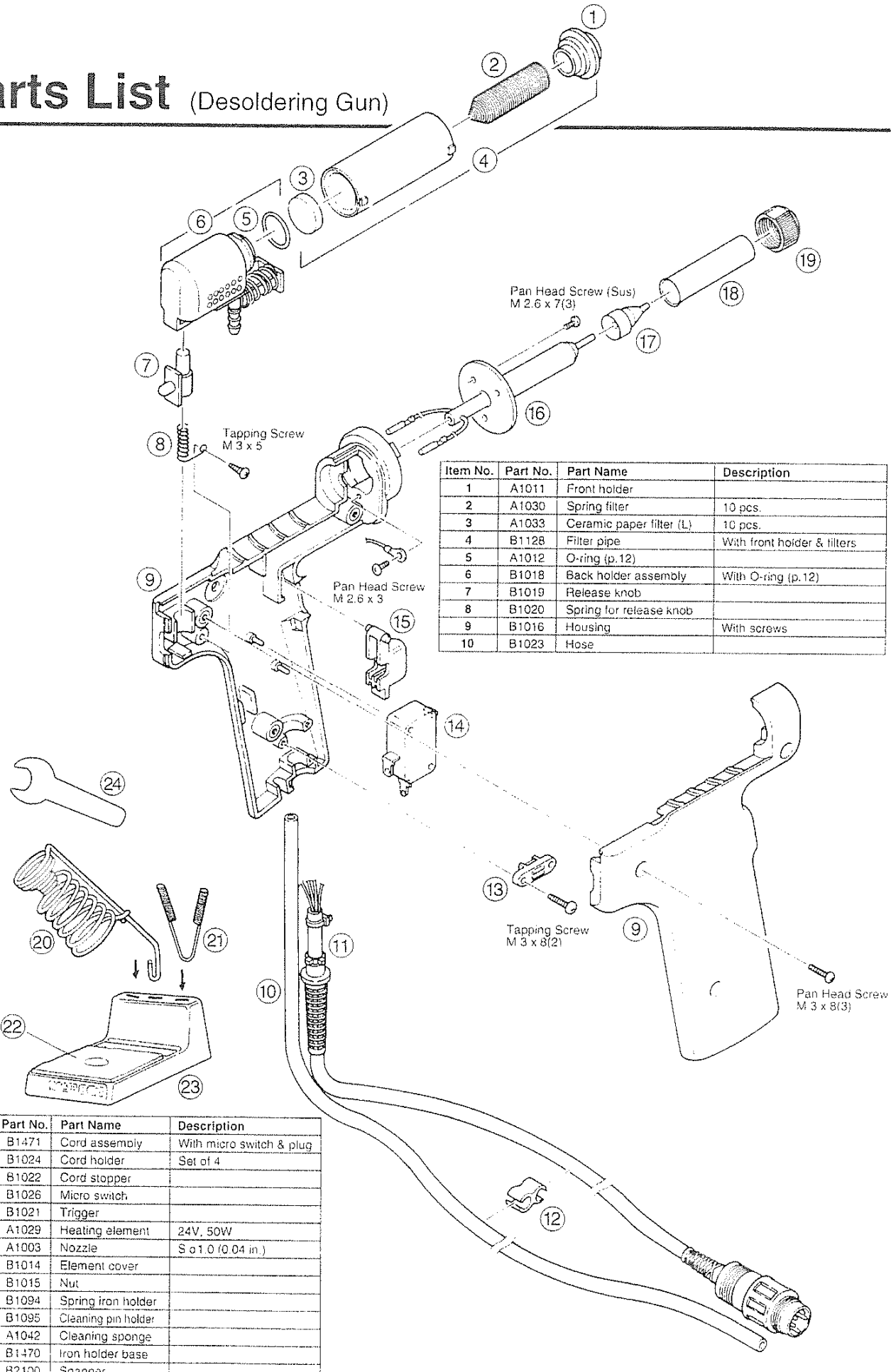

Item No.	Part No.	Part Name	Description
1	A1011	Front holder	
2	A1030	Spring filter	10 pcs.
3	A1033	Ceramic paper filter (L)	10 pcs.
4	B1128	Filter pipe	With front holder & filters
5	A1012	O-ring (p.12)	
6	B1018	Back holder assembly	With O-ring (p.12)
7	B1019	Release knob	
8	B1020	Spring for release knob	
9	B1016	Housing	With screws
10	B1023	Hose	

Item No.	Part No.	Part Name	Description
11	B1471	Cord assembly	With micro switch & plug
12	B1024	Cord holder	Set of 4
13	B1022	Cord stopper	
14	B1026	Micro switch	
15	B1021	Trigger	
16	A1029	Heating element	24V, 50W
17	A1003	Nozzle	Size 1.0 (0.04 in.)
18	B1014	Element cover	
19	B1015	Nut	
20	B1094	Spring iron holder	
21	B1095	Cleaning pin holder	
22	A1042	Cleaning sponge	
23	B1470	Iron holder base	
24	B2100	Spanner	

Specifications

Name	HAKKO 470B
Power Consumption	110W
• Station	
Part Name	Station
Output Voltage	24V~
Vacuum Generator	Vacuum pump, double cylinder type
Vacuum Pressure (Max)	80kpa (600 mm Hg) (24 in Hg)
Suction Flow	15 l/min.
Voltage Leakage	Under 2 mV (TYP. 1.2 mV)
Ground Resistance	Under 2 Ω
Outer Dimensions (l x w x h)	260 x 165 x 135 mm (10.24 x 6.50 x 10.24 in.)
Weight	Approx. 3.8 kg (8.4 lbs.)

• Replacement Parts

Part No.	Part. Name / Specification
A1002	Nozzle S $\phi 0.8$ mm (0.03 in.)
A1003	Nozzle S $\phi 1.0$ mm (0.04 in.)
A1004	Nozzle $\phi 0.8$ mm (0.03 in.)
A1005	Nozzle $\phi 1.0$ mm (0.04 in.)
A1006	Nozzle $\phi 1.3$ mm (0.05 in.)
A1007	Nozzle $\phi 1.6$ mm (0.06 in.)

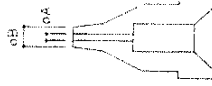

Part No.	ϕA	ϕB
A 1002	0.8 (0.03 in.)	1.8 (0.07 in.)
A 1003	1.0 (0.04 in.)	2.0 (0.08 in.)

Part No.	ϕA	ϕB
A 1004	0.8 (0.03 in.)	2.3 (0.09 in.)
A 1005	1.0 (0.04 in.)	2.5 (0.1 in.)
A 1006	1.3 (0.05 in.)	3.0 (0.12 in.)
A 1007	1.6 (0.06 in.)	3.0 (0.12 in.)

• Desoldering Gun

Part Name	Hakko 802
Part No.	C1054
Power Consumption	24V AC, 50W
Temperature	380°C – 480°C (716°F – 896°F)
Insulation Resistance	Over 300 MΩ at 420°C (790°F)
Nozzle Inside Diameter	$\phi 1.0$ (0.04 in.) (Nozzle S, Standard)
Outer Dimensions (w x h)	135 x 174 mm (5.31 x 6.85 in.)
Weight (w/o cord, hose)	Approx. 200g (0.44 lbs.)

Part No.	Part. Name / Specification
B1215	Cleaning pin for heating element
B1086	Cleaning pin for $\phi 0.8$ mm (0.03 in.) nozzle
B1087	Cleaning pin for $\phi 1.0$ mm (0.04 in.) nozzle
B1088	Cleaning pin for $\phi 1.3$ mm (0.05 in.) nozzle
B1089	Cleaning pin for $\phi 1.6$ mm (0.06 in.) nozzle
B1302	Cleaning drill for $\phi 0.8$ mm (0.03 in.) nozzle
B1303	Cleaning drill for $\phi 1.0$ mm (0.04 in.) nozzle
B1304	Cleaning drill for $\phi 1.3$ mm (0.05 in.) nozzle
B1305	Cleaning drill for $\phi 1.6$ mm (0.06 in.) nozzle

Part No.	Part. Name / Specification
B1128	Filter pipe w/ front holder & filters
A1009	Ceramic paper filter (S) for filter case 10 pcs
A1033	Ceramic paper filter (L) for filter pipe 10 pcs
A1030	Spring filter 10 pcs
A1029	Heating element 24V, 50W
A1028	Silicone grease
A1042	Cleaning sponge

Condition of Measurement

• Insulation Resistance

The insulation resistance was measured between the nozzle and the lead of the heating element using a 500 V DC insulation resistance meter.

Caution: The insulation resistance cannot be measured between the nozzle and the power plug as the transformer between the secondary part (heating element) and the primary part acts as an insulator.

• Voltage Leakage

The voltage leakage was measured between the nozzle and the grounding plug at a temperature of 480°C (896°F) using an AC mV meter.

Caution: Be sure to ground the unit before measuring the voltage leakage.

• Specifications are subject to change without notice.

Wiring

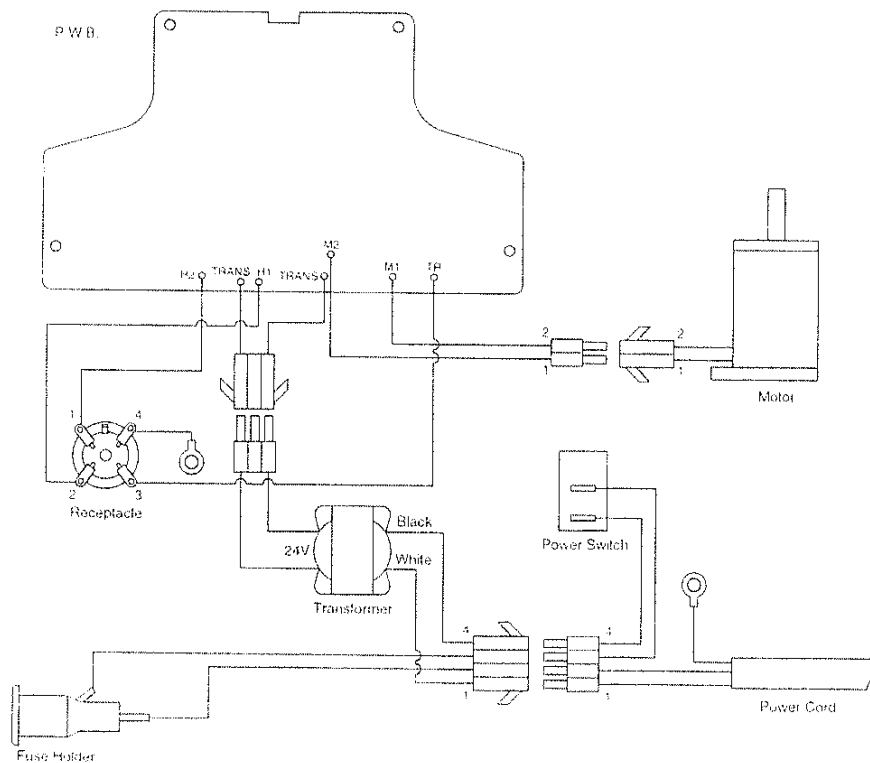



HAKKO CORPORATION

HEAD OFFICE

4-5, SHIOKUSA 2-CHOME, NANIWA-KU, OSAKA, 556-0024 JAPAN

TEL:+81-6-6561-3225 FAX:+81-6-6561-8466

<http://www.hakko.com>

AMERICAN HAKKO PRODUCTS, INC.

25072 ANZA DR. SANTA CLARITA, CA 91355, U.S.A.

TEL: (661) 294-0090 FAX: (661) 294-0096

Toll Free (800)88-HAKKO www.hakkousa.com

4 2 5 5 6

April 2000

MA00010AB000404